



PILOT AIR SILENT SERIES



Instruction and Maintenance Manual

Dear Customer,

Thank you for choosing Pilot Air.

In order to get the best performance out of this product, please read this manual carefully.

To avoid incorrect operation of the equipment and possible physical risk to the operator, please read and strictly follow the instructions contained in this manual.

Note, these instructions are in addition to the safety rules that apply in the country where the air compressor is installed.

Before packing for shipment, each machine undergoes a rigorous test to ensure the absence of any manufacturing faults and to demonstrate that the device can perform all the functions for which it has been designed.

This manual must be maintained available in any moment for future references and it has to be intended as inherent part of the relevant machine.

Due to the continuous technical evolution, we reserve the right to introduce any necessary change without giving previous notice.

Should you experience any trouble, or for further information, please do not hesitate to contact us.

Best Regards,



PILOT AIR COMPRESSORS

<http://www.pilotair.com>

Phone: 1300 667 579

Email: service@pilotair.com.au / spares@pilotair.com.au

Thank you for purchasing a SILENT electrocompressor, a choice that reflects your technical knowledge and ability to appreciate quality products.

Our compressors are made using high quality materials. They are controlled during the various stages of production in line with ISO 9001 quality certification and undergo a series of tests to ensure compliance with performance specifications.

This electro-compressor is safe and versatile. Long service life is guaranteed, subject to compliance with these instructions for use and maintenance, which satisfy the requirements of Machinery Directive 2006/42/EEC, implemented in Italy by Presidential Decree 81/08.

If the compressor is not used in accordance with these instructions, operation may be impaired and the guarantee will become void. In that case we decline responsibility for any damage that may be caused to people, animals or things in connection therewith.

This handbook addresses those who purchase our silent compressors for use in professional applications. It contains all the necessary product data and instructions for installation, safe use and maintenance.

Read these instructions carefully and keep them for future reference. Compliance with all that set forth herein is an essential prerequisite in order to guarantee safety. Regular maintenance and ongoing care and inspections are essential in order to guarantee correct operation, efficiency and long service life. The user is responsible for duly recording all operations to service the compressor, oil consumption values, routine and extraordinary maintenance operations and for ensuring strict compliance with that set forth in this handbook.

The compressors described in this handbook are built to satisfy the requirements of Legislative Decree 81/08 and the applicable technical standards pursuant to the CE declaration of conformity attached hereto, and thus conform to all European safety requirements.

The following pages contain all the information and explanations that are necessary in order to guarantee correct operation and maintenance. They also provide instructions for implementing the compressed air system. Should you require any additional information, please do not hesitate to contact our technicians.

According to current legislation, any modifications to safety devices, unless previously authorised by the manufacturer, will immediately render the guarantee void and the user will be held responsible for any damage to third parties that may be caused in connection with said modifications.

The manufacturer hereby declines all civil and criminal liability for any damage or injuries that may be caused as a result of non-compliance with that set forth in this handbook.

WARNING

These instructions for use and maintenance constitute an integral part of the compressor and must be kept in the vicinity of the equipment or by the personnel responsible for using the equipment.

1	General Information	5
2	Captions for Illustrations	7
3	Handling And Controls	8
4	Installation	9
5	Safety Rules	11
6	Engineering	13
7	Main Features	15
8	Principles of Operations	17
9	Putting into Service	18
10	Operation	19
11	Compressed Air Settings	20
12	Maintenance	21
13	Troubleshooting	22
14	Guarantee	25
15	EC Declaration of Conformity	26
16	Summary of Maintenance and Inspection Operation	27
17	Wiring Diagram	28
18	Warrant Terms and Conditions	42

1. General Information

PRODUCT DATA

In all communications with the manufacturer, please make reference to the information contained on the plastic adhesive label attached to the guarantee on the last page of this handbook or on the data plate [fig.1] on the compressor.

FAC SIMILE PRODUCT IDENTIFICATION PLATE (Fig 1)

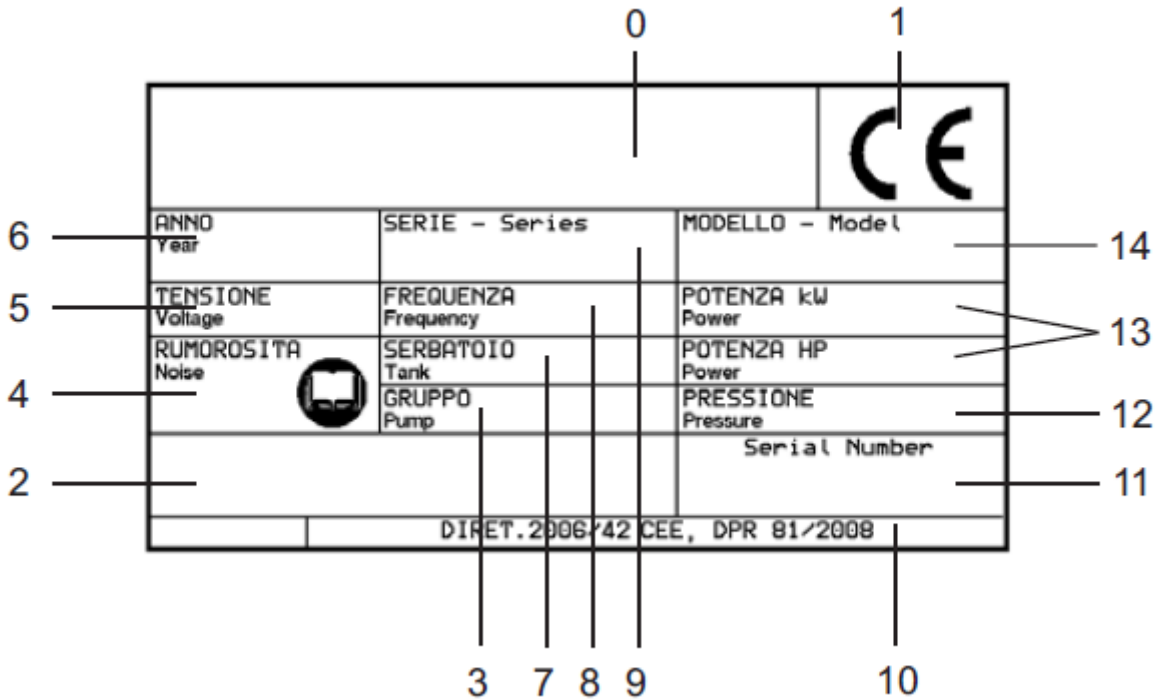

- 0** Producer
- 1** CE Mark
- 2** Bar code for the identification
- 3** Pump
- 4** Noise level
- 5** Feeding voltage
- 6** Year of production
- 7** Tank capacity
- 8** Net frequency
- 9** Series Name
- 10** Standards Identification
- 11** Serial number
- 12** Maximum working pressure
- 13** Power of the engine
- 14** Model

DESCRIPTION OF THE MACHINE

The SILENT series comprises a range of reciprocating, single stage and dual stage compressors with oil-free or splash lubrication and vertical or “V” twin cylinders, for use in industrial applications. The various models can be direct motor coupled or V belt driven by single-phase electric motors with direct starting or three-phase motors with direct or delta-star starting. They have independent forced ventilation, a control panel and operating parameters display. The main difference between single and dual stage models consists in the way the air is compressed. In single stage compressors, the air is sucked in and compressed once before being made available. In dual stage compressors the air is compressed in two stages; first of all by the low pressure piston and then by a piston with a smaller diameter (high pressure). In terms of performance, the difference between the two types consists in their maximum operating pressure, which is 10 bar for single stage compressors and 11 or 13 bar for dual stage compressors. In order to guarantee compliance with project quality and safety specifications pursuant to ISO 9001 certification and European directives, all parts used to manufacture our compressors are tested for thermal resistance and mechanical strength. These tests consist of exposing parts to temperatures and mechanical stress values that exceed those encountered during normal operation. Electric motors comply with all statutory requirements and have class F insulation.

Our compressors are suitable for:

- **Supplying painting plants**
- **Handling lift trucks**
- **Supplying assembly lines**
- **Sandblasting**
- **Supplying presses and pneumatic tools**

Before use, make sure that the specific application requires an air capacity that does not exceed 60% of the compressor’s capacity.

This is particularly important when supplying air to brake-clutch assemblies of mechanical presses, in order to ensure the safety of operators and prevent possible malfunctioning of twin valves.

Noise emissions under pressure fall within the limits defined by Presidential Decree 81/08, and operators are not therefore required to wear protective ear muffs.

CRITERIA FOR USE

Silenced compressors should NOT be activated CONTINUOUSLY but made to operate for approximately 60% of running time. The user must take into consideration the requirements of the specific application (amount of air needed, maximum pressure, total number of air outlets, continuity thereof), in order to define the most appropriate method of use and define the capacity of the external sump in order to guarantee continuous delivery while ensuring maximum efficiency. Examples of recommended sump capacities are:

1. **200 litres for the ZT500 model**
2. **300 litres for the ZT750 - ZT850 models**
3. **500 litres for the ZT850 - ZT1100 models**
4. **1000 litres for the ZT1500 - ZT2200 – ZT2600 models**

Compressors in the SILENT 1 series incorporate a 24 litre sump inside the cabinet and do not therefore require the use of an external sump. If the user wishes to use an external sump in any case, a capacity of 100 litres is recommended.

2. Captions for Illustrations

SILENT 1 (Fig 3)

- 0) Data plate
- 1) Complete compressor
- 2) Fastening screws on side panels
- 3) Motor
- 4) Motor-pump assembly baseframe
- 8) Motor pulley
- 9) Air outlet to user
- 10) Transverse dampener
- 11) V belts
- 12) Flywheel
- 13) Adjustable foot
- 14) Power supply cable
- 15) Safety lock
- 17) Hot air vent grille
- 18) Rear panel
- 19) Pump unit
- 20) Upper cover
- 24) Delivery hose
- 25) Removable side panels
- 27) Oil level indicator
- 28) Check valve
- 29) Oil drainage valve
- 30) Calibrated safety valve
- 31) Air sump
- 32) Longitudinal dampener
- 33) Oil refill and drainage plug
- 36) Fastening screws on control panel
- 37) Front panel
- 38) Safety lock on cover
- 40) Control panel
- 41) Pressure switch
- 44) Air intake filter
- 45) Intake hose

SILENT2 (Fig.4)

- 0) Data plate fig.
- 1) Complete compressor
- 2) Fastening screws on side panels
- 3) Motor
- 4) Motor-pump assembly baseframe
- 5) Spiral intake hose mod.1100
- 6) Silencer mod.1100
- 7) Belt tension adjustment plate
- 8) Motor pulley
- 9) Air outlet to user
- 10) Transverse dampener
- 11) V belts
- 12) Flywheel
- 13) Adjustable foot
- 14) Power supply cable
- 15) Safety lock
- 16) Oil drainage valve mod. 1100
- 17) Hot air vent grille
- 18) Rear panel
- 19) Pump unit
- 20) Upper cover
- 21) Auxiliary fan
- 22) N.O. head blowdown solenoid valve
- 23) Silencer on solenoid valve
- 24) Delivery hose
- 25) Removable side panels
- 26) Distributor on unit
- 27) Oil level indicator
- 28) Check valve
- 29) Oil drainage valve mod. 500-750-850
- 30) Calibrated safety valve
- 31) Pulsation dampener
- 32) Longitudinal dampener
- 33) Oil refill and drainage plug
- 34) Silencer mod. 500-750-850
- 35) Delivery hose
- 36) Fastening screws on control panel
- 37) Front panel
- 38) Safety lock on cover
- 39) Electrical panel
- 40) Control panel
- 41) Pressure switch
- 42) Electric fan thermostat
- 43) Thermal alarm thermostat
- 44) Air intake filter
- 45) Spiral intake hose mod. 500-750-850

SILENT4 (Fig.5]

- 0) Data plate
- 1) Complete compressor
- 3) Motor
- 4) Motor-pump assembly baseframe
- 7) Belt tension adjustment plate
- 8) Motor pulley
- 10) Dampener
- 11) V belts
- 12) Flywheel
- 16) Oil drainage valve
- 17) Hot air vent grille
- 18) Rear panel
- 19) Pump unit
- 20) Upper cover
- 21) Auxiliary fan
- 24) Delivery hose
- 25) Removable side panels
- 27) Oil level indicator
- 28) Check valve
- 30) Calibrated safety valve
- 31) Pulsation dampener
- 33) Oil refill and drainage plug
- 35) Delivery hose
- 37) Front panel
- 39) Electrical panel
- 40) Control panel
- 41) Pressure switch
- 42) Electric fan thermostat
- 43) Thermal alarm thermostat
- 44) Air intake filter

3. Handling and Controls

SILENT compressors can be manoeuvred with ease. Simply fasten the compressor to a pallet and move by means of a fork lift truck or transpallet.

Before moving, check the maximum load supported by the specific surface. When moving, take care not to jolt the compressor and make sure that the load is balanced centrally on the forks.

Prior to delivery, all compressors designed for use in professional applications undergo specific tests to simulate all foreseeable problems, as prescribed by law. All compressors are inspected before leaving our works.

Unfortunately, we cannot exclude the possibility of damage to the compressor during transportation. The user should therefore inspect the compressor before setting it to work, to ensure that it is in perfect condition, and monitor the first hours of operation, in order to detect any faults.

The compressor is supplied fully assembled.

To connect the compressor to the compressed air system, only use hoses (51) [fig.6], that are at least 60 cm long and of a suitable size in relation to the outlet on the compressor (see table 4).

4. Installation

POSITION

In order to facilitate maintenance or repair operations, the SILENT range of compressors all come with removable panels. Always make sure there is enough room between the compressor and any walls or other machinery to enable easy access to service points.

Silenced compressors generate a considerable amount of heat and must therefore be installed in environments where there is adequate ventilation. The number and size of the openings through which air is able to enter the operating environment must be sufficient to reduce the temperature in said environment. If windows or other openings are inadequate to guarantee a constant supply of fresh air, ventilators must be installed. These must be powerful enough to lower the temperature in the operating environment, with a capacity of 15-20% more than the air that is needed to cool the total number of compressors that have been installed [Fig.8].

WARNING:

Pursuant to ATEX 94/9/EEC, this compressor is not designed for use in environments where there is a risk of explosion. Air inlets must therefore be arranged in such a way as to prevent dust, sawdust, paint, gas or explosive mixtures from entering the environment. Do not install the compressor in particularly dusty environments or close to gas emissions.

Compressors designed for professional use are built to operate in ambient temperatures of +5°C / +35°C. For installation in environments where the temperature falls outside this range, please seek the advice of our technicians. Install the compressor directly on a horizontal floor with no special foundations, avoiding the use of the platforms supplied or wooden surfaces.

The amount of air needed by the compressor, the minimum size of the premises in which compressors are installed and number and size of openings in order to ensure adequate ventilation are shown in **table 6**.

Captions for figure 7

- 1) Complete compressor
- 46) Hot air vent
- 47) Hot air vent fan

Captions for figure 8

- 1) Complete compressor
- 48) Main circuit breaker with valves
- 49) Compressor power supply cable
- 50) Air outlet valve
- 51) Hose for connection to the system
- 52) Air cooler
- 53) Receiver sump
- 54) Pressure gauge
- 55) Safety valve
- 56) Air outlet gate valve
- 57) Ceramic filter
- 58) Air outlet from sump to user
- 59) Dryer by-pass
- 60) Air outlet from cooler to user
- 61) Dryer
- 62) Sump blowdown valve
- 63) Automatic condensate drainage valve
- 64) Air gate valve
- 65) Condensate drainage valve filter
- 66) Compressor connecting manifold
- 67) Connection to other compressors
- A) Diagram of receiver sump
- B) Diagram of cooler, sump and dryer
- C) Diagram showing set of compressors and receiver sump
- D) Diagram showing set of compressors, with cooler, sump and dryer

4. Installation

Electrical connections

Electrical connections must be effected by a qualified technician. Install an outlet with main circuit breaker and adequate fuses (see table 5).

Compressors must always be connected to the ground. The sections of the power supply line as shown in the table are approximate and refer to a conductor with a maximum length of 50 meters. For very long lines (more than 50 meters long) or in case of very high ambient temperatures, recalculate the size of these sections.

WARNING:

The first time the compressor is switched on, check all the connecting clamps and tighten if necessary.

The compressor must only run with all parts of the cabinet closed.

Before connecting the compressor to the mains outlet, make sure that the factory mains voltage corresponds to that of the compressor. Noncompliance may result in permanent damage to the machine and will render the guarantee void. Before using the compressor, make sure that the supply circuit is connected to the ground as specified by Presidential Decree 81/08 (or equivalent statutory requirements applicable in each member state).

Connect the electro-compressor to the power supply by means of the electric cable that is provided. Avoid the use of inadequate extensions, as these could impair operation. Never repair or modify power supply cables or use cables that have been damaged or cut. Replace any cables that show signs of wear with cables of the same type (available from authorised service centres).

Connection to the air supply

To connect the compressor to the compressed air system, only use hoses that are at least 60 cm long. These must be of a suitable size in relation to the outlet on the compressor.

To ensure efficiency, the compressed air system must consist of a loop or closed-circuit in order to reduce pressure drop to a minimum and make sure that the pressure along the entire line is as homogenous as possible. Use suitably-sized seamless steel pipes (Mannesmann) or hoses made of flexible materials that are suitable for use with compressed air. If metal pipes are used, these should preferably have internal galvanized protection.

WARNING:

Hoses must have a diameter that is 1/2" bigger than that of the air outlet valves so that the relative pressure drop does not affect compressor efficiency by reducing the minimum operating pressure, which would undermine the efficiency of the whole system. Take care not to reduce the sections of hoses or pipes along any part of the circuit, and use wide radius elbows to limit the amount of pressure that is lost. Install a suitable number of air gate valves on the sump outlet and along the air supply circuit to enable maintenance work to be carried out along the line. Make provisions for connecting an emergency unit for use in case the primary compressor is not available. Use suitably-sized valves and fittings in relation to the air outlet. The air supply circuit must have a slope of at least 1% in order to drain any condensate that may deposit in the lowest parts of the circuit. Use the automatic blowdown or purge valves on standard models to drain condensate [fig.8].

Never use hoses of a smaller size than specified herein

Safety is guaranteed by the fact that the machine conforms to the relative safety requirements, as certified by the CE mark and declaration of conformity (which certifies that the machine meets the minimum safety requirements defined by the European Directive). However, the general condition of installations at the place in which the machine is used can affect safety considerably and the responsibility for ensuring regular maintenance thereof lies exclusively with the user.

The machine is constructed to satisfy the requirements of Presidential Decrees 81/08 and must be maintained in its original condition.

No additions, modifications or alterations may be made to electric or electronic logic, connections or the type of components installed on the machine, unless previously approved by the manufacturer. All machines bearing the CE mark must be supplied with the technical file containing details as regards all the solutions that have been implemented in order to guarantee compliance with statutory safety requirements and applicable standards.

Any modifications or operations other than routine or extraordinary maintenance operations, or that alter original machine functioning, will render the guarantee void and constitute breach of safety rules. In that case, the user will be civilly and criminally liable.

RESIDUAL RISKS

Due to the fact that human behaviour is not 100% foreseeable, it is impossible to construct machines that are absolutely safe under all operating conditions.

Pursuant to the requirements of the Machinery Directive (Presidential Decree 81/08) it is not possible to eliminate the following residual risks:

1. Electrical risk

The risk is confined to maintenance workers who perform operations on the machine without first making sure that it has been disconnected from the electrical mains. Should it be essential for operations to be carried out with the machine energised, all maintenance workers must be furnished with dielectric gloves and insulating equipment to guarantee at least a double barrier against the risk of electrocution.

2. Risk of coming into contact with moving parts

The risk is confined to maintenance workers who violate protection devices, i.e. external compressor casing, in order to access moving gear. Parts may start to move suddenly if the pressure switch is triggered automatically. Safety is guaranteed by means of fixed guards. These can only be removed after making sure that the machine has been disconnected from the electrical power supply.

5. Safety Rules

3. Risks in connection with pressurized parts.

All parts designed to carry pressurised liquids are oversized and are checked and tested before leaving our works. Their mechanical strength is adequate to withstand hostile operating conditions without generating any problems. However, problems may arise in connection with unexpected malfunctioning of parts available on the market, such as pipe fittings, dehumidifiers, hoses. Check the condition of these parts regularly, avoid stress due to collisions, verify the condition of threads on fittings, make sure that all seals are securely in place and that there are no cuts on the surface of rubber parts.

4. Risks in connection with the lubricants used.

Not all lubricants are approved for use or are able to guarantee long service life and efficiency of parts. Only use the lubricants specified in these instructions for use and maintenance. Dispose of all lubricants according to applicable legal and safety guidelines.

5. Risks in connection with the use of the compressor in environments with potentially explosive dust or highly flammable solvent or liquid fumes.

The compressor comprises electrical components suitable for use in non-flammable environments only. Compressors required to operate in environments exposed to the aforesaid risks must be modified before use. Please contact the manufacturer.

6. Risk of fire.

Some parts of the compressor may become extremely hot (99° C) and represent a potential fire hazard in the presence of substances that are highly flammable or with a flash point below that temperature. Places where compressors are installed must be kept clean at all times. Do not stack unnecessary materials in the immediate vicinity of the compressor, especially combustible solvents or paint.

7. Risks in connection with the alteration of the micro-climate inside the works.

When running, the compressor takes in and processes air. Incorrect installation could have adverse effects on the health and safety of those inside the building.

8. Risk of noise.

The user is responsible for the safety of the machine and the use thereof, and must immediately replace any parts or accessories that are faulty or that may undermine safety. Should any of the safety rules set forth in this handbook fail to comply with local laws, the user must comply with the set of rules that guarantee the highest degree of safety.

All parts used to manufacture the machine are of a suitable type and size in relation to power and performance specifications. The SILENT **compressor** primarily consists of:

- 1) Soundproof cabinet
- 2) Reciprocating piston pump unit
- 3) Electrical components
- 4) Control and instrument panel

1) SOUNDPROOF CABINET

The cabinet features a streamline, modern design. It consists of a solid baseframe that supports the uprights, which in turn support the upper frame. The outer casing consists of side and front panels and a cover. The cabinet is epoxy powder coated and cured at 180°C. The panels are made of a soundproof and self-extinguishing material to ASTM-D-1962-68 specifications. The baseframe is palletisable and incorporates height-adjustable feet.

2) RECIPROCATING PISTON PUMP UNIT

The extensive range comprises single stage and dual stage compressors, from 1.5 to 18.5 Kw (2HP÷25HP), all of which incorporate highly reliable pump units to meet the requirements of all professional and industrial applications. In the SILENT1 version, the pump unit and motor are assembled on a baseframe, which is fastened to 24 litre dampener; in the SILENT2 and SILENT4 versions, these assemblies are fastened directly to the structure by means of extremely efficient vibration dampening pads. The air inlets on the cabinet are arranged in order to maintain the pump unit cool at all times, to maximise efficiency and performance. The SILENT2 and SILENT4 versions incorporate high-capacity electric fans that are controlled by a thermostat and operate independently of the compressor.

3) ELECTRICAL COMPONENTS

Electrical panel

In the SILENT series, the electrical panel is installed inside a space at the front of the cabinet. In the SILENT1 version, this panel is accessed by removing the cover. In the SILENT2 and SILENT4 versions it can also be accessed by unscrewing the two screws on the top of the control panel and turning this down. The panel is made of extremely reliable components and comprises power and auxiliary devices.

Motor

SILENT compressors incorporate single-phase electric motors with direct starting or three-phase motors with direct or delta-star starting. Motors are built to class F insulation and IP54 protection. All models incorporate thermal cutout devices.

4) CONTROL AND INSTRUMENT PANEL

The control panel on the COMPACT [fig.11] and SILENT1 [fig.10] models comprises:

- 40.15 - Direct air outlet.
- 40.16 - Outlet for air controlled by the pressure reducer for direct supply to pneumatic tools
- 40.17 - Pressure control
- 40.18 - Pressure gauge for controlled pressure
- 40.19 - Pressure gauge for direct pressure
- 40.20 - Pressure switch cover
- 40.20.1 - START-STOP switch
- 40.20.2 - Reset push button
- 40.20.3 - Fastening screw on pressure switch cover, to enable direct access to the motor thermostat
- 40.20.4 - Condensate separator filter on air output circuit upstream of pressure control (SILENT1)
- 40.20.8 - Condensate drainage valve (SILENT1)
- 40.20.6 - Condensate receiver vessel
- 40.21 - Pressure switch cover anchor plate

N.B. To take the pressure switch cover off, backoff the fastening screws and remove the plate. The control panel on the SILENT2 and SILENT4 models has a polycarbonate membrane cover and incorporates an electronic circuit board with the “ON - OFF” switches and a series of LEDs, which constitute an auto-diagnostic system that supplies the compressor’s operating status in real-time [fig.14].

Captions fig.14

- 40 Control panel
- 40.0 - Polycarbonate membrane keypad
- 40.1 - Display diagram
- 40.2 - Hour meter
- 40.3 - Pressure gauge to measure line air pressure
- 40.4 - ‘Reset motor thermal cutout status indicator: when, following an overload, the motor thermal cutout is triggered, the machine stops and the red LED switches on to indicate the fault.
- 40.5 - ‘Motor turning in wrong direction’ status indicator: at the request of the customer, a phase sequence relay can be installed that is triggered and prevents the machine from starting if the motor turns in the wrong direction. The fault is signalled by the dedicated red LED.
- 40.6 ‘Thermal alarm’ status indicator: when the temperature inside the cabinet exceeds the threshold value the thermostat is triggered and stops the machine and the relative red LED switches on.
- 40.7 - ‘Electric fan on’ status indicator: this indicates that the fans have been switched on to vent the hot air
- 40.8 - ‘Motor running’ status indicator: this indicates correct motor operation.
- 40.9 - ‘Voltage on’ status indicator: this indicates that the compressor is energised and stays on even when the machine is not running.
- 40.10 - Red stop pushbutton
- 40.11 - Green start pushbutton
- 40.12 - Control and auto-diagnostic circuit board
- 40.13 - Circuit board fastening screws
- 40.14 - Adhesive wiring diagram [fig.16]

Head blowdown solenoid valve

This is of the Normally Open type and is installed on SILENT2 and SILENT4 models

Check valve

Prevents return air flow

Safety valve

This is set in correspondence to the compressor's operating pressure. It is sealed with lead and cannot be adjusted.

N.B. Never tamper with the valve.

Airsump

This 24 litre sump is only present on SILENT1 models. It absorbs all the pressure pulsations so that the command and control devices can be connected to the compressor.

Pulsation dampener

The 3 litre dampener installed on the SILENT2 version and 9 litre dampener on the SILENT4 absorb pressure pulsations so that the command and control devices can be connected to the compressor.

Air intake filter

Dry air filters with interchangeable cartridges are used.

Intake silencer

Reduces the noise generated during normal compressor operation (SILENT1 and SILENT2).

Pressure switch

This is set to a pressure of 10 bar in single stage models (SILENT1) and 11 bar in dual stage versions. It can also be set to 13 bar in special applications (SILENT2 and SILENT4).

Electric fan thermostat

Set to 60°C. This triggers the electric fans when the temperature inside the cabinet exceeds 60°C. It is present in SILENT2 and SILENT4 models.

Thermal alarm thermostat

Set to 90°C. This stops the compressor when the temperature inside the cabinet exceeds 90°C. It is present in SILENT2 and SILENT4 models.

Hour meter

Displays the number of hours of operation and is included in SILENT2 and SILENT4 models.

Pressure gauge

Displays the pressure of the air delivered to the line.

Captions on the electrical panel SILENT2 and SILENT4 [fig.15]

- 14 Power supply cable
- 39 Electrical panel
 - 39.1 - Terminal strip with coupling system for connecting diagnostic board
 - 39.2 - Fuse holder
 - 39.2.1 - Fuse F1 for fan 400V, 2A.
 - 39.2.2 - Fuse F2 for transformer 400V, 2A.
 - 39.2.3 - Fuse F3 for auxiliaries 24V, 4A
 - 39.3 - KV fan power contactor.
 - 39.4 - RT motor thermal relay.
 - 39.4.1 - Motor thermal switch control (already calibrated at works)
 - 39.4.2 - Reset motor thermal switch
 - 39.5 - KY star power contactor
 - 39.6 - KD delta power contactor
 - 39.7 - K motor power contactor
 - 39.8 - RSF phase sequence relay (included at the customer's request)
 - 39.9 - Delta-star timer set to 2-3 sec.
 - 39.9.1 - Delta-star timer control, settings from 0 to 10 sec.
 - 39.10 - Transformer for auxiliary circuit 230/400V IN - 0/24V OUT.
- 40.12 - Control and auto-diagnostic board
 - 40.12.1 - Terminal strip on circuit board for connector.

Circuit diagram:

When the compressor is switched on, the head blowdown solenoid valve (N.O. normally open) is triggered and closes, thus blocking blowdown (in motors with delta-star configuration, the solenoid valve closes when it receives the signal from the delta power contactor). Each time the machine is stopped, either intentionally or accidentally, this solenoid valve unloads the pressure from the head in the section of the hose between the unit and the check valve.

When the pressure inside the sump reaches the maximum value that has been set, the pressure switch stops the machine until the pressure falls to the re-start value. These pressure values are set by the pressure switch manufacturer.

Compressors with delta-star starting that also incorporate the OFF-LOAD RUN function are designed to run continuously. This means that the compressor runs even when the maximum operating pressure has been reached, but without compressing air in the sump. This function is useful for heavy-duty applications that would require excessively frequent startups in normal configuration and result in excessive amounts of energy being absorbed and wasted. The off-load run function is available in 2 different versions: pressure switch with solenoid valve or pilot valve.

When the maximum pressure value is achieved, the pressure switch sends the signal to a N.C. (normally closed) 3-way solenoid valve that allows the compressed air to be unloaded from the sump and triggers the pistons on the head of the pump unit, which block the intake vanes. The motor continues to run but the air intake is interrupted. In order to guarantee safety, a second pressure switch is installed, with a pressure setting that is higher than the OFF-LOAD RUN value (usually 11 bar). When the line sends a new request for air, the pressure switch moves to the minimum pressure value, the solenoid valve stops activating the pistons and the compressor takes in air. The pilot valve works the same way as the pressure switch and solenoid valve, by triggering the pistons to stop and then restart suction.

Before starting the compressor, the following preliminary checks must be carried out (in strict compliance with the instructions set forth herein):

1. **Power supply voltage and frequency must correspond to those specified on the machine data plate.** A LED (40.9)[fig.14] on the control panel of SILENT2 and SILENT4 versions switches on to indicate that the compressor is energized
2. The pump unit **must turn to the RIGHT**, when looking at the machine from the front. This can be verified by removing the front panel of the cabinet. If requested by the customer, a phase sequence relay can be installed. This prevents startup in case of incorrect phase direction and signals the fault condition by means of the dedicated LED.
3. **When using lubricated compressors, check the oil level through the transparent plug (27) [fig.3-4-5].** This should be at the half-way mark on the display (transparent plug) on the pump unit. (In case of incorrect oil levels, refer to the chapter entitled "Maintenance Operations"). The compressor is supplied with the following type of oil:
 - Q8 Haydn 100 for single-phase machines with less than 2.2 kW (3HP).
 - Q8 Haydn 150 for three-phase machines with more than 2.2 kW (3HP).
4. Models in the SILENT1 series:
Make sure that the condensate drain valve under the sump [fig.12] is closed.
5. Models in the SILENT1 series:
Check that the pushbutton on the pressure switch [fig.13] is set to "OFF - 0".

9.Putting into Service

After completing the preliminary checks described above, connect the plug to the mains outlet.

To start models in the SILENT1 series, pull up the pushbutton on the pressure switch and set to “ON - 1” [fig.13], (in three-phase motors make sure that the motor turns in the direction shown by the arrow). On models in the SILENT2 and SILENT4 series, the ‘voltage on’ status indicator on the control panel lights up (40.11) [fig.14] and stays on even when the compressor is not being operated. This LED only switches off when the main circuit breaker is disconnected. At this stage, all the other LEDs on the control panel are off. The compressor is ready to be started: press the green pushbutton, which is marked with the word “ON”. The machine starts and the ‘motor running’ LED switches on to indicate this condition (40.8) [fig.14]. Provided the machine continues to run normally, the compressor delivers air to the system and only stops when the pressure inside the sump reaches the maximum pressure setting. The compressor re-starts when the pressure inside the sump reaches the minimum pressure setting on the pressure switch.

WARNING:

Should the motor turn in the wrong direction, stop the machine, invert one phase and re-start.

If the machine incorporates the phase sequence relay, in case of an inverted phase when the machine is switched on, the motor does not start and the function signals the fault by means of the dedicated LED and the thermal alarm LED, arranged in series (40.5)(40.4) [fig.14].

To switch off compressors in the SILENT1 series, press the pushbutton on the pressure switch down to the “OFF - 0” position. [fig.13]. For compressors in the SILENT2 and SILENT4 series, switch the machine off by pressing the red pushbutton marked “OFF” (40.10) [fig.14].

WARNING:

Always use the pushbutton on the instrument panel to switch the compressor off. Do not pull the cable to disconnect the plug. Do not expose the compressor to severe temperatures.

During normal operation, the use of extensions, of any diameter or length, is not recommended.

10.Operation

When running, the compressor is controlled directly by the pressure switch. This disconnects the power supply to the motor when the pressure inside the sump reaches the value that has been set on the pressure switch (10 bar for single stage compressors, 11 bar for dual stage compressors or 13 bar for special applications) and reconnects the power supply when the pressure inside the sump falls by approximately 2 bar in relation to the maximum pressure allowed. This specific setting is defined during testing according to customer specifications.

WARNING:

- This reciprocating compressor should be made to operate for 60% of running time.
- Compressors incorporate a safety valve on the sump with a pressure setting that is equal to the maximum operating pressure setting on the pressure switch. This is triggered in the event of a pressure switch malfunction in order to vent excess air.
- Never, under any circumstances whatsoever, adjust the compressor in order to exceed the maximum pressure setting.
- To avoid the risk of burns, do not touch the connecting hoses, cylinder head, motor, check valve or any other parts of the compressor that may become hot while the compressor is running and for some minutes after it has stopped.

11.Compressed Air Settings

Compressors in the SILENT1 series have 2 air outlets: 1 is a direct outlet and 1 consists of a valve connected to a pressure reducer. It is therefore possible to connect the sump to the direct outlet or use the valve to connect pneumatic tools. If the latter is the case, proceed as follows:

- Set the required pressure by means of the pressure control knob (40.17) [fig.10-11]. Proceed as follows: make sure the knob is free before turning; if that is not the case, pull up to release the safety catch. Turn the control knob clockwise to increase output pressure or anti-clockwise to reduce it. The operating pressure value is displayed on the pressure gauge B (40.18), while the reading on the pressure gauge A (fig.40.19) indicates the pressure inside the sump.
- Connect the hose from the pneumatic tool to the air outlet and open. After normal use, return the control knob to the closed position and make sure that the sump is empty by unloading any residual air from the valve.

Models in the SILENT2 and SILENT4 series only have a direct air outlet from the sump.

During operation, never:

- Stand the compressor on sloping surfaces;
- Cover the compressor or use in poorly ventilated environments;
- Use the compressor in the rain or in severe weather conditions;
- Remove the condensate blowdown plug;
- Direct the jet of air towards people, animals or highly volatile materials (powders, thinners, etc...);
- Carry out maintenance operations.

SAFETY RULES CONCERNING MAINTENANCE OPERATIONS

Compliance with the provisions of all safety laws is essential before and while performing any maintenance operations.

1) Electrical components:

Disconnect the compressor from the mains supply before carrying out operations on the electrical panel or rotating parts.

2) Air supply circuit:

Disconnect the compressor from the mains supply and make sure that there is no pressure in the internal circuits and sump before carrying out operations or disassembling parts of the pneumatic circuit.

3) Control panels:

Disconnect the compressor from the mains supply before disassembling any panels, especially before opening the control panel.

Should you have any problems in connection with the compressor, our technical department is at your complete disposal to carry out any operations during the period of guarantee in addition to all scheduled maintenance operations or other activities after the guarantee has expired.

MAINTENANCE

Correct and regular maintenance is essential in order to ensure efficiency and long service life. For this purpose, we have drawn up a list of all the maintenance operations and checks (see Table 1), including the frequency with which these operations should be carried out. The hours of service between maintenance operations defined in the table are those recommended in order to ensure efficiency.

The frequency of operations may be changed according to ambient operating conditions. Routine maintenance operations need not be carried out by specially trained maintenance personnel. However, the pump unit and other important parts should preferably be overhauled by qualified technicians or maintenance operators. If necessary, contact your dealer.

Unless otherwise specified, the following information refers to the complete range.

THE COMPRESSOR DOES NOT START:

Possible causes

- 1) No electricity supply;
- 2) Auxiliary circuits fuse (39.2.3)[fig.14] blown (SILENT2 and SILENT4);
- 3) Line fuse (39.2.2) [fig.14] blown (SILENT2 and SILENT4);
- 4) No voltage supply to line contactor coil K (SILENT2 and SILENT4);
- 5) Line contactor coil K disconnected (SILENT2 and SILENT4);
- 6) Motor thermal cutout has been triggered (in SILENT2 and SILENT4 models the dedicated LED switches on);
- 7) In SILENT2 and SILENT4 models, if the phase sequence relay is used, the motor may be turning in the wrong direction and the dedicated status indicator will be switched on.
- 8) The compressor is pressurised;
- 9) Pressure switch (41) [fig.15] malfunction.

Solutions

- 1) Check the external protection and voltage supply of each phase;
- 2) Replace the fuse and find the cause of the fault. In case of further problems, seek the advice of a qualified technician;
- 3) Replace the fuse and find the cause of the fault. In case of further problems, seek the advice of a qualified technician;
- 4) Verify the correct operation of the transformer;
- 5) Verify the correct operation of the coil;
- 6) Reset the motor thermal cutout;
- 7) Invert two phases. If the problem persists, jumper the two terminals 1 and 4 in the ELECTROMATIC version and make sure that the motor turns in the right direction (which must correspond to the direction of the arrow on the motor);
- 8) Check the pressure gauge and, in case of pressure, empty the sump
- 9) Verify the electromechanical efficiency of the pressure switch.

THE MOTOR STOPS AND BRINGS THE COMPRESSOR TO A STANDSTILL

Possible causes

- 1) Status indicator (40.6) [fig.14] on: ambient temperature exceeds nominal values.
- 2) Status indicator (40.6) [fig.14] on: electric fan out of order.
- 3) Status indicator (40.4) [fig.14] on: motor overload
- 4) Mechanical faults of the pump unit

Solutions

- 1) Increase ventilation of the premises and vent hot air. Make sure that no airways in the cabinet are clogged. Check the voltage and current of each motor phase.
- 2) Jumper the two fast-on connectors to verify correct thermostat operation, (43) [fig.4-5] verify the correct operation of the KV 39.3 power contactor and the electric fan.
- 3) Check the voltage, consumption of individual phases and thermostat setting.
- 4) Check the level and quality of the oil. Overhaul the unit.

THE COMPRESSOR STOPS BECAUSE THE THERMAL CUTOUT IS TRIGGERED

Possible causes

- 1) Insufficient voltage supply to motor terminals.
- 2) 'Motor overload' status indicator on (40.4)[fig.14].
- 3) Incorrect thermal cutout setting.
- 4) Solenoid valve mechanism stuck in closed position.
- 5) Pump unit resistance malfunction.

Solutions

- 1) Check circuit sizing and do not use extensions.
- 2) Measure energy consumption by individual phases and verify correct unit operation.
- 3) Reset the thermal cutout.
- 4) Replace the solenoid valve.
- 5) Remove the belt and verify correct pump operation, check the level and quality of the oil and correct motor off-load operation.

THE SAFETY VALVE OPENS

Possible causes

- 1) Incorrect pressure switch setting.
- 2) Incorrect safety valve setting.
- 3) Solenoid valve mechanism blocked, during offload operation the pressure continues to rise.

Solutions

- 1) Reset the pressure switch.
- 2) Replace with other valves of the same approved type. Bear in mind that safety valves are sealed pressure components that are fundamental for machine safety and must be approved by official supervisory bodies.
- 3) Replace the solenoid valve.

POOR OR LOW CAPACITY, PRESSURE DOES NOT INCREASE

Possible causes

- 1) Clogged air intake filter (44) [fig.2-3-4-5].
- 2) Belts slack or worn.
- 3) Leaks from fittings.
- 4) Mechanical faults in the pump unit.

Solutions

- 1) Clean or replace the filter.
- 2) Tension or replace belts.
- 3) Inspect fittings using soapy water.
- 4) Seek the help of a qualified technician to overhaul the unit

IRREGULAR VARIATIONS IN OIL LEVEL

Possible causes

- 1) Excessive consumption.
- 2) Leaks.
- 3) Tendency to emulsify and increase.

Solutions

- 1) Overhaul the pump and replace piston rings.
- 2) Define critical leak points and overhaul.
- 3) Move the compressor to a less humid and warmer environment and change oil more often.

EXCESSIVE NOISE AND VIBRATIONS

Possible causes

- 1) Loose or worn parts.
- 2) Unit noisy due to wear.
- 3) Compressor handled incorrectly.
- 4) Head blowdown hoses broken.

Solutions

- 1) Check that bolts and nuts are tight.
- 2) Overhaul the pump unit.
- 3) Improve floor supports.
- 4) Restore original configuration to make the compressor operate more quietly.

14. Guarantee

This compressor has been tested and is supplied ready for use. It is guaranteed for 12 months as from the date of delivery stamped on the form, which must be returned to the manufacturer and/or importer within ten days.

The guarantee is only valid for customers who operate in accordance with all legal requirements and is subject to compliance with all the rules as regards installation, safety and use set forth herein.

During the period of guarantee, the manufacturer will repair or replace free of charge any parts that, following inspection at the works, are found to have been faulty at source. In that connection the manufacturer's decision is final.

The guarantee only covers manufacturing defects and does not include responsibility for direct or consequential damage to people, animals, or things. Any unauthorised tampering or modifications to the compressor will render the guarantee void.

This guarantee does not cover the motor, pressure switch or any parts that, in relation to the specific use thereof, are subject to wear, such as seals, valves, etc. The guarantee does not cover electrical parts in case of improper use, as defined with the relative suppliers.

The guarantee does not provide for compressors to be returned to the manufacturer unless previously agreed upon. In that case, delivery will be carriage free.

Any additional costs in connection with inspection at the customer's works, disassembly, reassembly or transportation by our technicians in order to repair faults that cannot be attributed to the manufacturer will be charged to the customer.

The guarantee does not cover damage due to negligence or improper use.

15.EC DECLARATION OF CONFORMITY

with registered office in

in the person and under the responsibility of its legal representative,

Mr

hereby certifies that:

- compressor _____ model _____ serial number _____
- was manufactured in the European Community
- and designed and built to meet the minimum safety requirements defined by Presidential Decree 2006/42/EEC European Directive implemented in Italy by Presidential Decree 81/08
- the machine was constructed using asbestos-free materials
- the materials used to manufacture the machine do not constitute a health hazard for operators
- the technical file is available at the manufacturer's head office for inspection by the competent supervisory bodies.
- the compressor was supplied to the customer complete with the instructions for use and maintenance, which constitute an integral safety component.
- the aforesaid instructions for use contain the list of residual risks.

Date

Signed by

The legal representative

TABLE Nr. 1

MAINTENANCE AND CHECK (condition of middle difficulty)				
INTERVENTION	Weekly	Monthly	Every 500 y	Every 1000 h
Condensation outlet	●			
Oil level check		■		
Safety valve check		●		
Belt tension check		●		
Oil leakage check		●		
Air filter cleaning		●		
Air cartridge change			●	
Rating check			●	
General inside cleaning				●
Total oil change				■
Belt and pulley check				●
Tube fastening check				●
Electric connection check				●
<p>  Recommended oil : Q8 HAYDN 150 Alternative mineral oil SAE40 (SAE20 for cold climates) </p> <p style="text-align: center;">DO NOT MIX DIFFERENT OILS !</p>				

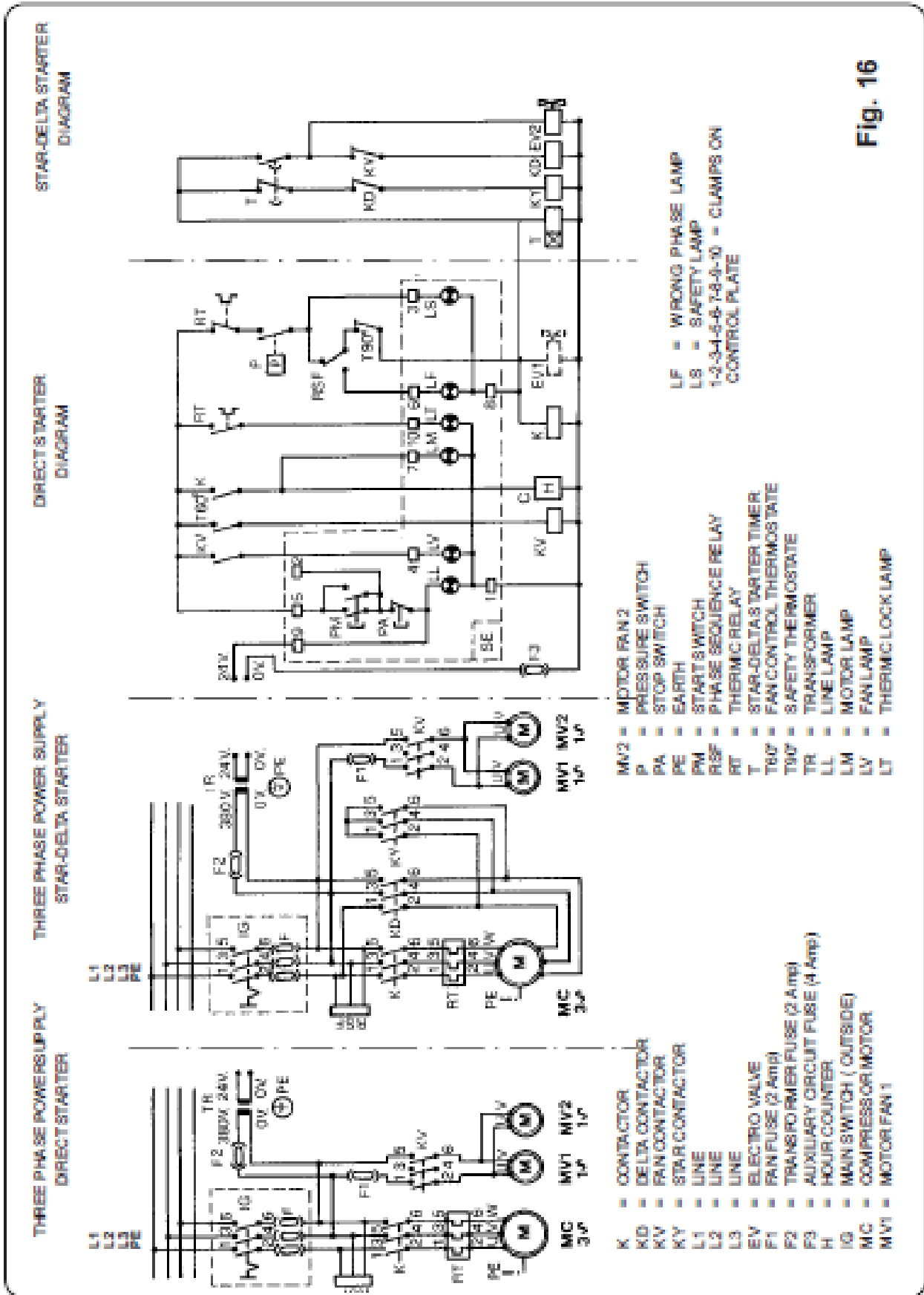

Fig. 16

SILENT

DATI TECNICI E MODELLI - TECHNICAL DATA AND MODELS - CARACTERISTIQUES THECNQUES ET MODELES - TECHNISCHE DATEN UND MODELLE - DATOS TECNICOS Y MODELOS												
SERIE - SERIES - SERIE - SERIE	SILENT 1				SILENT 2				SILENT 4			
	24 250	24 350	24 160	24 220	24 300	24 250	24 350	24 160	24 220	24 300	24 250	24 350
MODELLO - MODEL - MODELE - MOBILE - MODELO	2T 250	2T 350	2T 160	2T 220	2T 300	2T 250	2T 350	2T 160	2T 220	2T 300	2T 250	2T 350
POTENZA - POWER - PUISSANCE - MOTORLEISTUNG - POTENCIA	2	3	1,5	2	3	4	5,5	7,5	10	7,5	15	25
GRUPPO - PUMP - GROUPE - AGREGAT - CARBZAL	1,5	2,2	1,1	1,5	2,2	3	4	5,5	7,5	10,5	11	15
ARIA ASPIRATA - DISPLACEMENT - AIR ASPIRE - ABGESOGENE - LUFT - ADREASPIRADO	K11	K17	VB17 OL	K17 NL	K17 NL	K17 NL	K17 NL	K17 NL	K17 NL	K17 NL	K17 NL	K17 NL
ARIA FORNITA - FLOW RATE - AIR DEBITE - ABGEBENE LUFT - SUMINISTRADOS	220	321	118	225	321	413	591	727	1074	854	1464	2158
TARATURA PRESSORITATO - PRESSURE SETTING - PRESSION DE SERVICE - ARBEITSDRUCK - REGULATION PRESSION	13	19	6,9	14	19	25	35	44	64	51	87	129
PRESSIONE MASSIMA - MAX PRESSURE - PRESSION MAXI - MAX DRUCK - PRESSION MAXIMA	7,8	11,3	4,1	7,95	11,3	14,6	20,5	25,7	38	30,2	51	76
CELANDRI - CYLINDERS - CYLINDRES - ZYLINDER - CILINDROS	165	241	83	158	225	300	404	570	835	598	1085	1720
STADI - STAGES - ETAGES - STUFEN - ETAPAS	10	10	8	8	8	11	11	11	11	8	11	11
R.P.M.	145	145	116	116	116	160	160	160	160	116	160	160
RUMORE - NOISE - BRUIT - GERAUSCHFEBEL - RUMORISIDAD	2	2	2V	2	2	2	2	2	2	2	4V	4V
LWA	1	1	1	1	1	2	2	2	2	1	2	2
	1000	1000	1100	700	1000	1000	800	1000	1000	800	1000	1200
	60	63	60	63	64	65	65	68	68	65	69	71
	60	72	69	72	73	74	74	77	77	74	78	80

SILENT

DATI ELETTRICE TARIATURE - DATA FOR ELECTRIC CONNECTION - CARACTERISTIQUES TECHNIQUES ET TARAGES - ELEKTRISCHE DATEN UND EICHUNGEN DATOS ELECTRICOS Y REGULACIONES											
	SILENT 1			SILENT 2			SILENT 4				
	2P 250	2P 350	2P 450	2P 250	2P 350	2P 450	2P 250	2P 350	2P 450	2P 250	2P 350
SILENTE - SERIE - SERIE - SERIE MONOPHASE - SINGLE PHASE - MONOPHASE - ETRIPLASES - MONOFASEO											
	CORRENTE ASSORBITA - RATED CURRENT - COURANT DE PLAQUE - SPANNUNG - CORRIENTE SUPORTADA EN LA PLACA (A)										
	10,4	15,2	7,6	10,4	15,2						
TARIATURA TERMICO - THERMAL SETTING - TARAGE THERMIQUE - THERMISCHE EICHUNG - REGULACION TERMICA (A)											
	TARIATURA VS - SAFETY FUSELURE SETTING - TARAGE SOUPAPE DE SECURITE - SICHERHEIT EICHUNG - REGULACION VS										
	11,4	16,7	8,4	11,4	16,7						
TRIFASE - THREE PHASE - TRIFASE - DREHSTROM - TRIFASEO											
	CORRENTE ASSORBITA - RATED CURRENT - COURANT DE PLAQUE - SPANNUNG - CORRIENTE SUPORTADA EN LA PLACA (A)										
	15,9	22,7	11,4	15,9	22,7	11,4	15,9	21,7	29,6	12,5	17
CORRENTE ASSORBITA - RATED CURRENT - COURANT DE PLAQUE - SPANNUNG - CORRIENTE SUPORTADA EN LA PLACA (A)											
	TARIATURA VS - SAFETY FUSELURE SETTING - TARAGE SOUPAPE DE SECURITE - SICHERHEIT EICHUNG - REGULACION VS										
	3,4	5	2,5	3,4	5	2,5	3,4	5	17	12,5	17
DIRETTO - DIRECT - DIRECT - DIRECT - SCHALTUNG - DIRECTO											
TARIATURA TERMICO - THERMAL SETTING - TARAGE THERMIQUE - THERMISCHE EICHUNG - EICHUNG - REGULACION TERMICA (A)											
	STELLA/TROUING - STAR/DELTA - ETTOILE/TROUING - STERNOECK - ESTRELLA/TROUING										
	6,5	9,6	4,8	6,5	9,6	13,0	17,4	23,9	30,6	23,9	47,8
TARIATURA TERMICO - THERMAL SETTING - TARAGE THERMIQUE - THERMISCHE EICHUNG - REGULACION TERMICA (A)											
	FUSIBILE AUSIL MUDO - FUSES - FUSIBLE AUCCELAR - STICHERUNGEN - FUSIBLES BARRAS NO. (A)										
	3,8	5,5	2,8	3,8	5,5	7,5	10,0	13,8	18,8	13,8	27,5
TARIATURA VS - SAFETY FUSELURE SETTING - TARAGE SOUPAPE DE SECURITE - SICHERHEIT EICHUNG - REGULACION VS											
	TARIATURA VS - SAFETY FUSELURE SETTING - TARAGE SOUPAPE DE SECURITE - SICHERHEIT EICHUNG - REGULACION VS										
	2	2	2	2	2	2	2	2	2	2	2
TARIATURA VS - SAFETY FUSELURE SETTING - TARAGE SOUPAPE DE SECURITE - SICHERHEIT EICHUNG - REGULACION VS											
	TARIATURA VS - SAFETY FUSELURE SETTING - TARAGE SOUPAPE DE SECURITE - SICHERHEIT EICHUNG - REGULACION VS										
	11	11	9	9	9	11,5	11,5	11,5	11,5	9	11,5
TARIATURA VS - SAFETY FUSELURE SETTING - TARAGE SOUPAPE DE SECURITE - SICHERHEIT EICHUNG - REGULACION VS											
	TARIATURA VS - SAFETY FUSELURE SETTING - TARAGE SOUPAPE DE SECURITE - SICHERHEIT EICHUNG - REGULACION VS										
	160	160	130	130	130	167	167	167	167	160	167

SILENT

PESTE DIMENSIONI DI INGOMBRO - OVERALL DIMENSIONS AND WEIGHT - POIDS ET ENCOMBREMENT - AUSSENMASSE UND GEWICHTE - DIMENSIONES Y PESO												
SERIE - SERIES - SERIE - SERIE	SILUNT 1				SILUNT 2				SILUNT 4			
	COLLETTA		COLLETTA		COLLETTA		COLLETTA		COLLETTA		COLLETTA	
MODELLO - MODEL - MODELE - MODELO	27.250	27.350	27.450	27.550	27.650	27.750	27.850	27.950	27.1.000	27.1.100	27.2.000	27.2.500
PESO - WEIGHT - POIDS - GEWICHTE - PESO	103	110	105	125	130	147	168	182	230	185	360	400
kg												
DIMENSIONI - DIMENSIONS - ENCOMBREMENT - AUSSENMASSE - DIMENSIONES (mm)												
A	700				650				1400			
B	630				630				900			
C	1100				1100				1300			
D	110				110				110			
E	535				530				1000			
F					105				80			
FL												
G	692				692				1000			
H	146,5				146,5				146,5			
I	575				725				1270			
L	62,5				62,5				62,5			
M					115				120			
N	34"				34"				1"			
NI												

SILENT

CONTENUTO D'OLIO NEI COMPRESSORI SILENZIATI - OIL CONTENTS IN SILENT COMPRESSORS - QUANTITE D'HUILE DANS LES COMPRESSEURS SILENCIEUX - FULLMNGEN FÜR SILENT KOMPRESSOREN - CONTENIDO DEL ACEITE EN LOS COMPRESORES INSONORIZADOS													
SERIE - SERIES - SERIE - SERIE - SERIE	SILENT 1				SILENT 2				SILENT 4				
	COLLES				COLLES				COLLES				
	20-250	20-250	27-350	27-350	20-250	20-250	27-350	27-350	20-250	20-250	27-350	27-350	
MODELLO - MODEL - MODELE - MODELLE - MODELLO													
POTENZA - POWER - PUISSANCE - MOTORLEISTUNG - POTENCIA	2	3	1,5	2	3	4	5,5	7,5	10	7,5	15	20	25
GRUPPO - PUMP - GROUPE - AGREGAT - CABEZAL	1,5	2,2	1,1	1,5	2,2	3	4	5,5	7,5	5,5	11	15	18,5
LITRI DI OLIO - OIL CONTENTS - LITRES D'HUILE - FULLMNGEN INLITER - VOLUMEN(LIT)	K11	K17	MS7 OL	K17 RL	K17 RL	K25	K30	K30	K30	K35 RL	K60	K100	K100
	0,5	1	-	-	-	1,8	1,25	1,25	1,8	-	4	5	5
CONTENUTO D'OLIO NEI COMPRESSORI SILENZIATI - OIL CONTENTS IN SILENT COMPRESSORS - QUANTITE D'HUILE DANS LES COMPRESSEURS SILENCIEUX - FULLMNGEN FÜR SILENT KOMPRESSOREN - CONTENIDO DEL ACEITE EN LOS COMPRESORES INSONORIZADOS													
SERIE - SERIES - SERIE - SERIE - SERIE	SILENT 1				SILENT 2				SILENT 4				
	COLLES				COLLES				COLLES				
	20-250	20-250	27-350	27-350	20-250	20-250	27-350	27-350	20-250	20-250	27-350	27-350	
MODELLO - MODEL - MODELE - MODELLE - MODELLO													
VOL. NECESSARIO AL COMPRESSORE - AIR VOL. FOR COMPRESSOR - VOL. D'AIR NÉCESSAIRE AU COMPRESSEUR - KOMPRESORSETTES MOTRES LUFTVOLUMEN - VOL. DE AIRE NECESARIO PARA EL COMPRESOR (m³/h)	600	700	400	600	700	1100	1250	1500	1750	1500	2500	3000	3000
VOL. NECESSARIO AL LOCALE - AIR VOL. FOR ROOM - VOL. D'AIR NÉCESSAIRE AU LOCAL - MOTRES LUFTVOLUMEN - VOL. DE AIRE NECESARIO PARA EL LOCAL (m³/h)	600	660	660	660	660	1600	1600	2100	2000	2100	3600	5000	6100
APERTURA MINIMA DEL LOCALE - MINIMUM ROOM OPENING - OUVERTURE MINI DU LOCAL - MINESTOSORSE LUFTUFRSÖFFNUNGEN DES RAUMS - ABERTURA MINIMA DEL LOCAL (m²)	0,1	0,1	0,1	0,1	0,1	0,2	0,2	0,3	0,4	0,3	0,5	0,7	0,8

SILENT

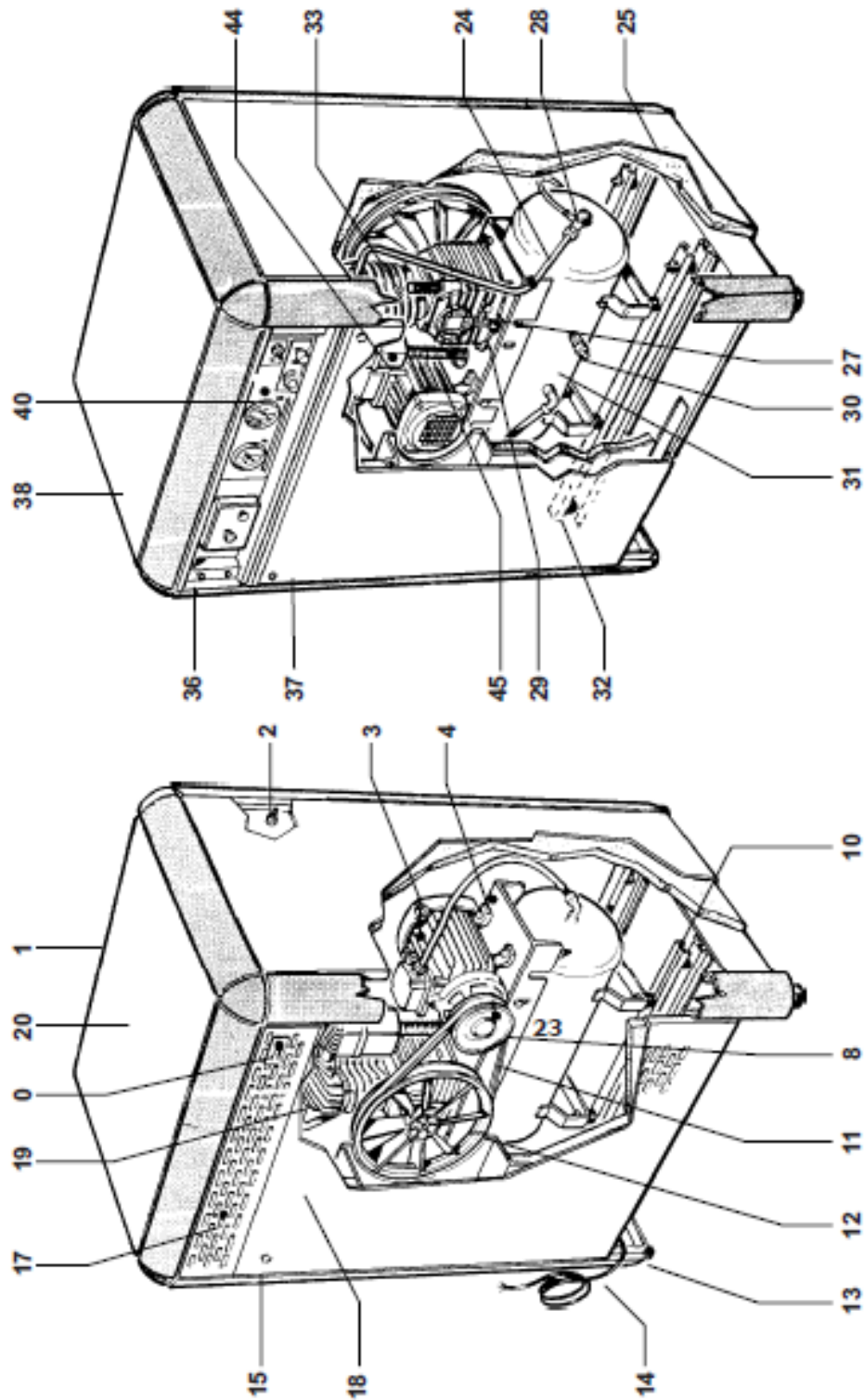

Fig.- Bild 3

SILENT

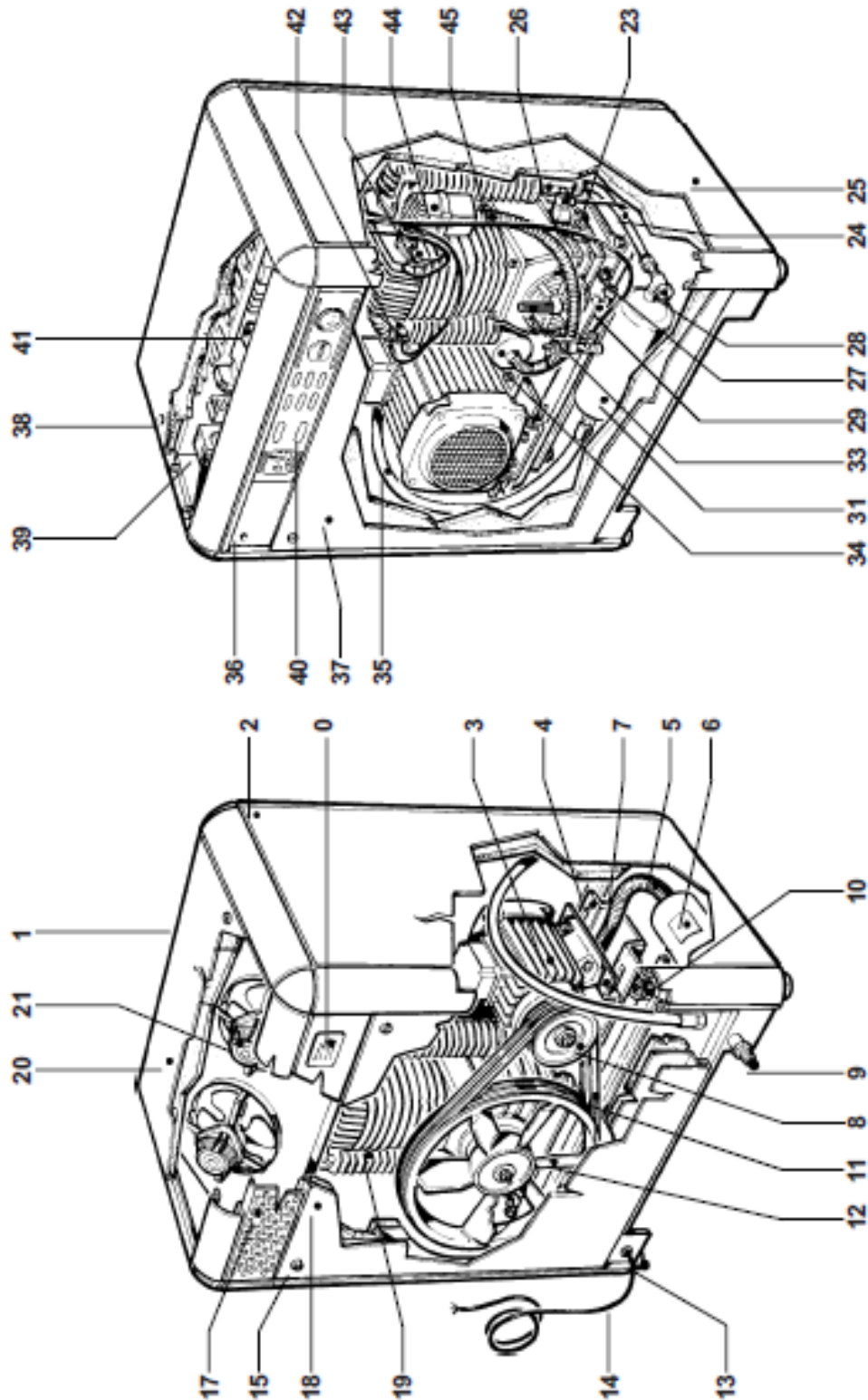

Fig.- Bild 4

SILENT

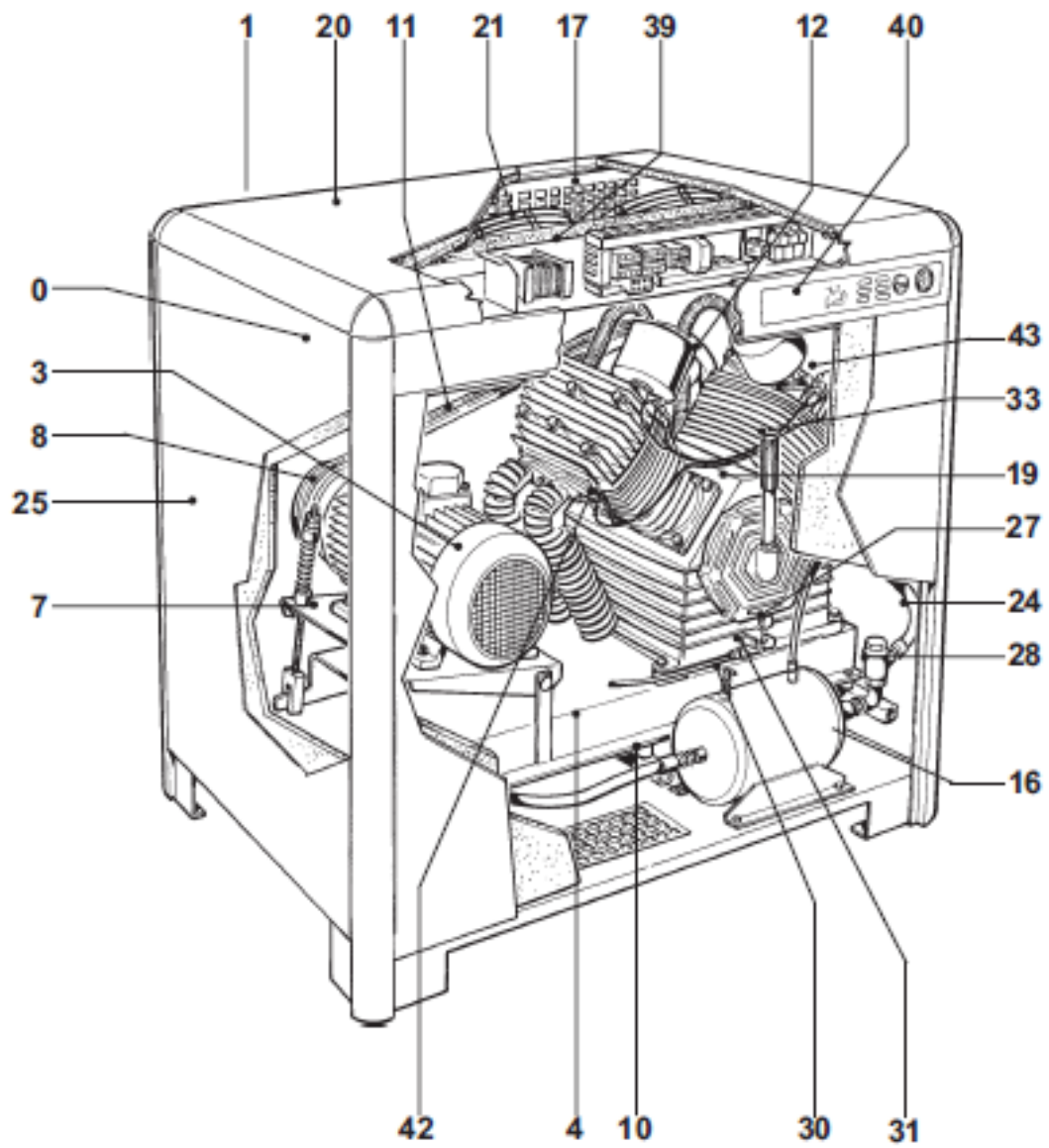

Fig.- Bild 5

SILENT

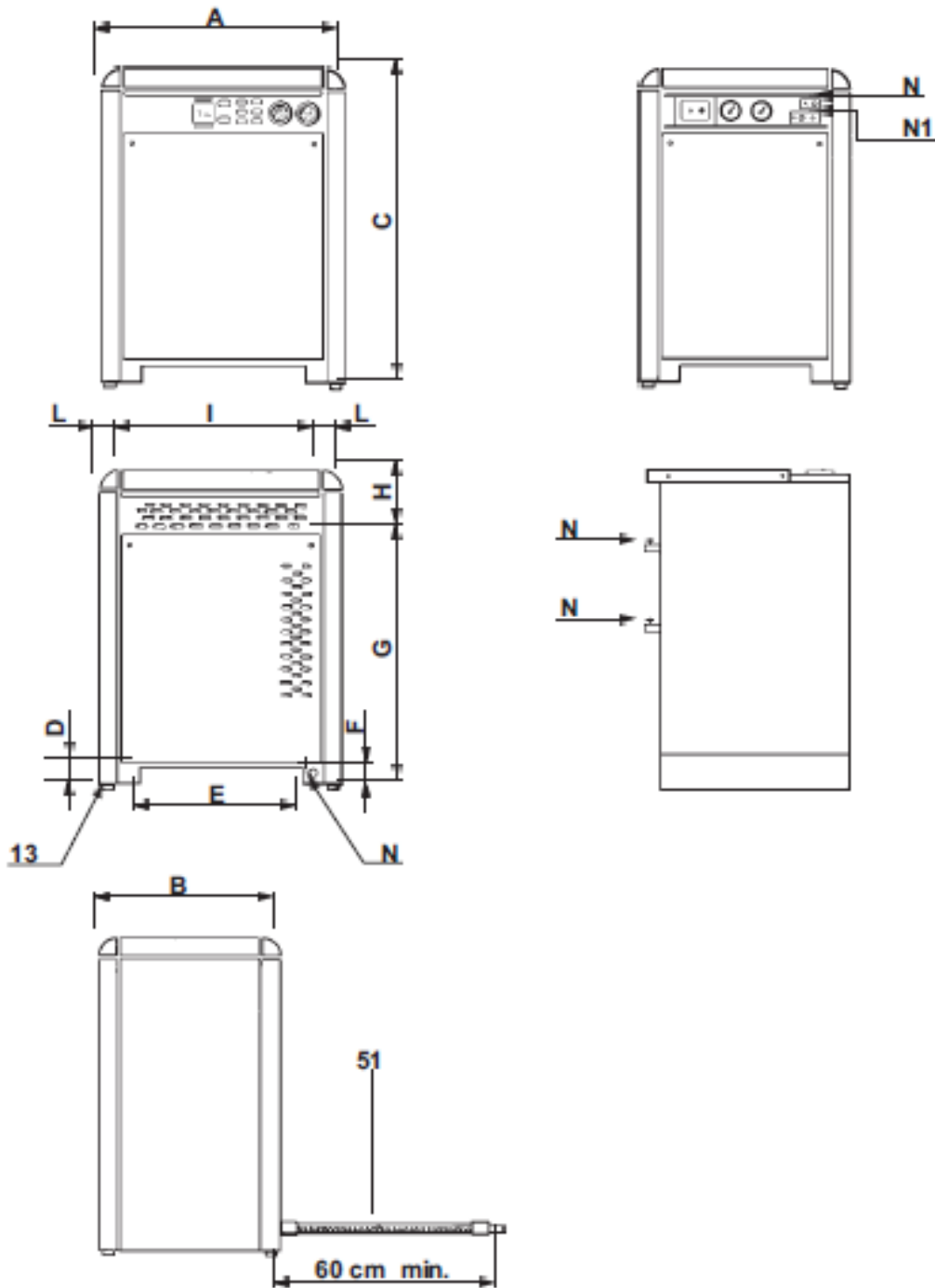
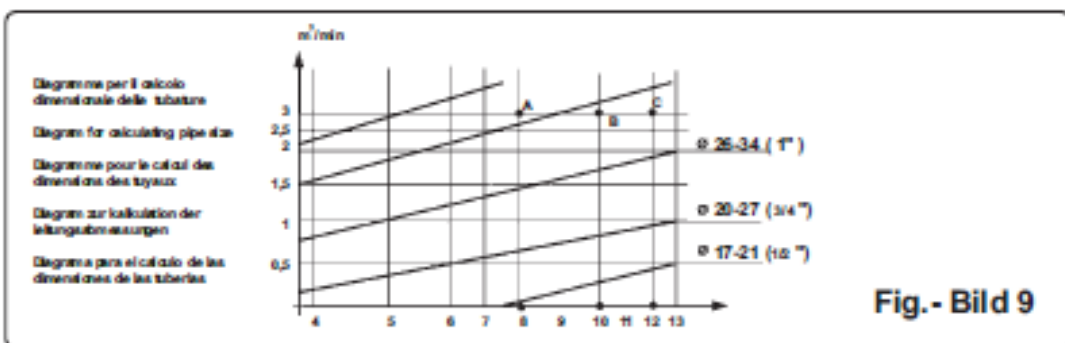
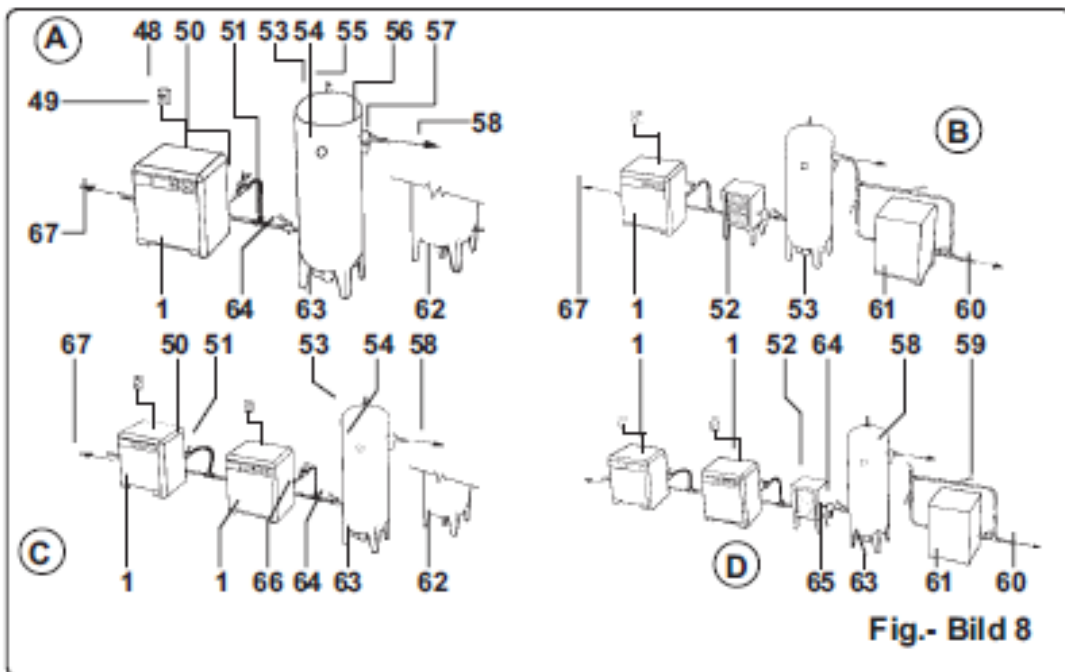
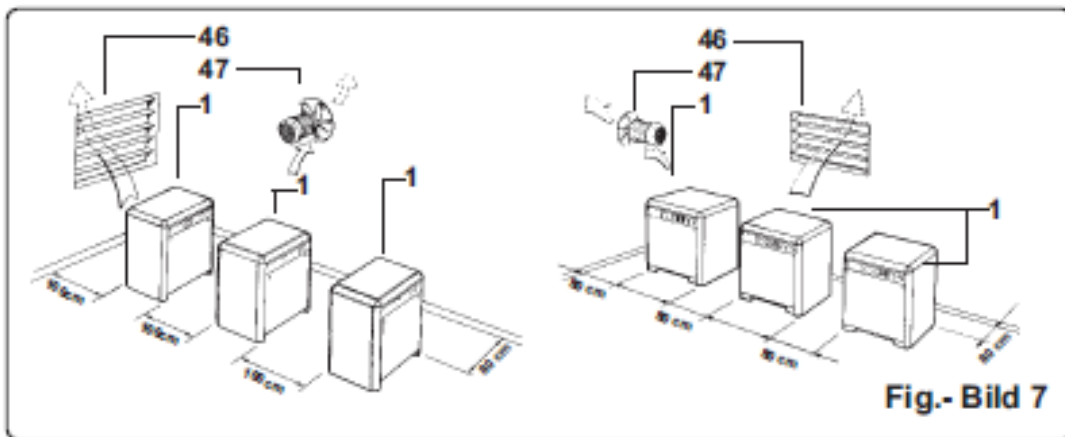
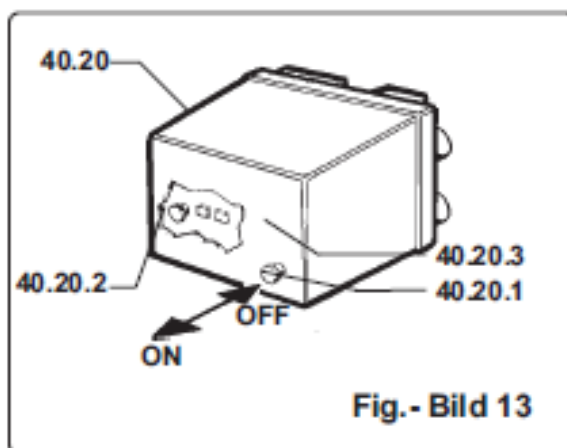
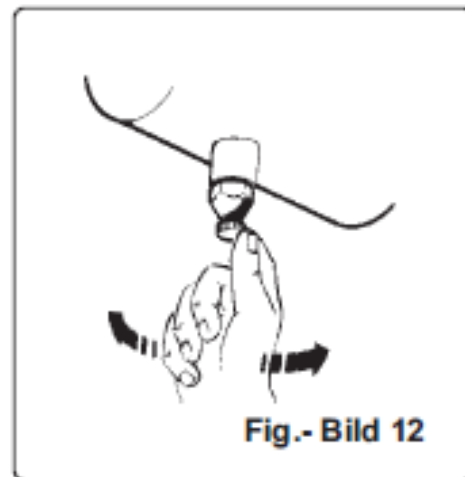
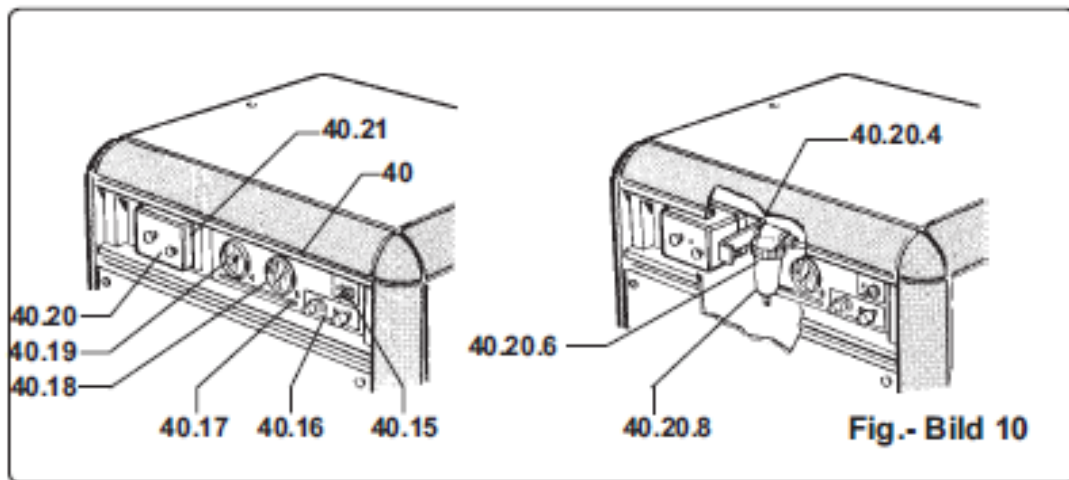

Fig.- Bild 6

SILENT



SILENT



SILENT

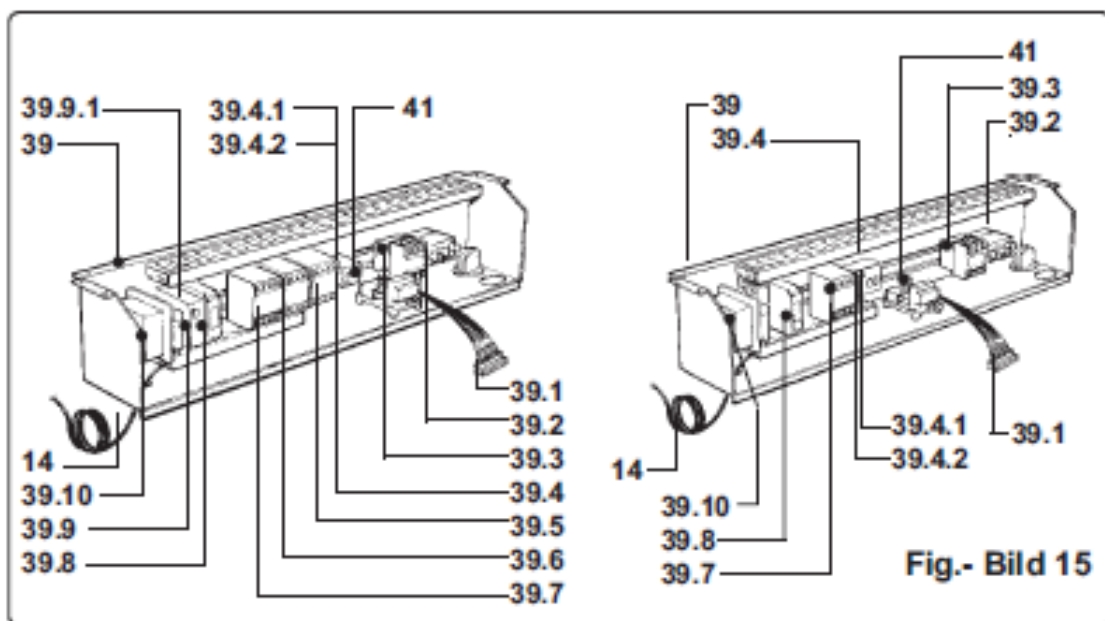
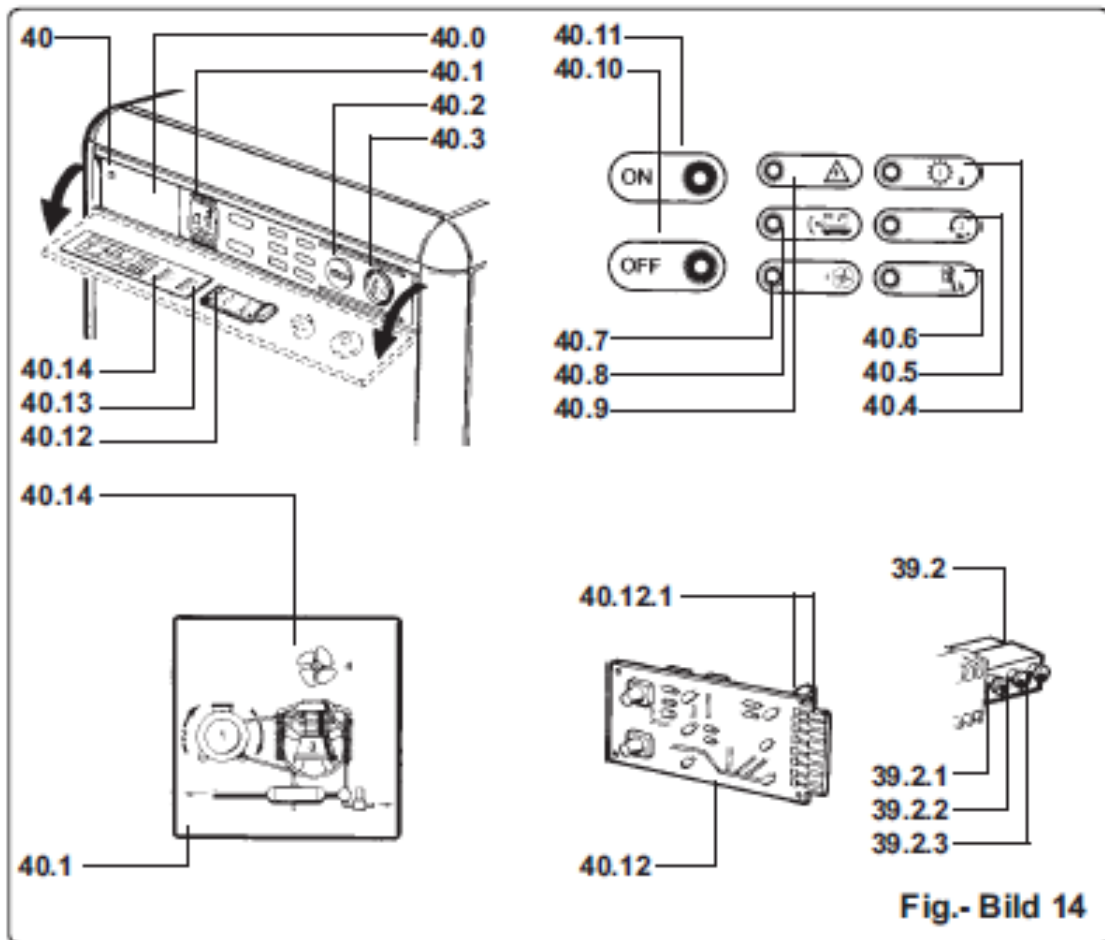

Warranty

Pilot Air Compressors Pty Ltd **manufactured goods - 1 Year Warranty and 3 Year Warranty (where applicable)**

(DATE)

Pilot Air Compressors Pty Ltd (**Pilot Air**) warrants to the first purchaser of goods (manufactured by it) (Product) from Pilot Air and the last purchaser prior to installation that, subject to compliance with the Conditions of Warranties below that:

1. For a period of 12 months from the date of purchase, the Product will be free from defects due to defective factory workmanship or materials; and
2. For a period of 12 months from the date of purchase that Pilot Air branded accessories supplied by Pilot Air will be free from defects due to defective factory workmanship or materials.
3. The compressor pump only (and excluding all other components of the unit) in the following units:
 - a. TM Series Units
 - b. Classic K Series Units
 - c. Petrol Industrial Series Units
 - d. Three Phase Industrial Series Units

will be free from defects due to defective factory workmanship or materials for a period of 3 years from the date of purchase.

4. The 'ALTA TEC', 'DCR', 'PAC' and 'FP' Series of Rotary Screw type compressors will be free from defects due to defective factory workmanship or materials for 3,000 working hours in the first 12 months from the date of purchase. This warranty is extended to a period of 2 years for the air end of the DCR PAC and FP Series Compressors.
5. Where compressors are powered with either petrol or diesel engines, the engine only is subject to the warranty provided by the manufacturer of the engine.
6. Non-Pilot Air accessories (meaning accessories which are not Pilot Air manufactured and branded) which are supplied by Pilot Air are not covered by this warranty. Purchasers are referred to the individual manufacturer's warranty. Purchasers can request a copy of the applicable warranties by contacting Pilot Air using the contact details below.

Warranty

Conditions of Warranties

The warranties specified herein are subject to the following conditions:

- (a) Pilot Air will not be liable for a breach of any of its warranties unless the Claimant provides proof of purchase of the Product and makes a written claim to Pilot Air at the address set out below, either within 30 days after the defect would have become reasonably apparent, or if the defect was reasonably apparent prior to installation, then the claim must be made prior to installation;
- (b) The warranties are not transferable;
- (c) The Product must be installed, operated, maintained and serviced strictly in accordance with the relevant Pilot Air literature current at the time of installation and must be installed in conjunction with the components or products specified in the Pilot Air literature. To obtain copies of such literature go to www.pilotair.com.au or telephone Pilot Air on (02) 9648 3099;
- (d) If the claimant chooses to rely upon any warranty specified herein the claimant's sole remedy under the warranty for breach of the warranty is (at Pilot Air's option) that Pilot Air will either supply replacement Product, rectify the affected Product or pay for the cost of the replacement or rectification of the affected product;
- (e) In the circumstances where the guarantees under the Australian Consumer Law do not apply in respect to the purchase of its Products, Pilot Air will not be liable for any losses or damages (whether direct or indirect) including property damage or personal injury, consequential loss, economic loss or loss of profits, arising in contract or negligence or howsoever arising. Without limiting the foregoing, Pilot Air will not be liable for any claims, damages or defects arising from misuse of the Product, inadequate maintenance and storage of the Product, repairs rendered necessary or arising from the use of non- genuine Pilot Air parts in the product, normal wear and tear maintenance of the Product, deterioration of any part of the Product due to normal wear and tear, work performed on the Product other than by an authorised Pilot Air service technician or their agent, use of the Product for any purpose other than which it was intended to be used, use of the Product after essential parts and accessories have been removed, operating the Product continuously under excessive load, and if the serial/model label has been removed or obscured on the Product;
- (f) In circumstances where the guarantees under the Australian Consumer Law do not apply in respect to the purchase of its Product/s: all warranties, conditions, liabilities and obligations other than those specified herein are excluded to the fullest extent allowed by law.

Warranty

- (g) Parts repaired or replaced under any warranty specified herein are warranted only for the remaining period of the original warranty period.
- (h) All defective parts that are the subject of a claim under any warranty specified herein become the property of Pilot Air.
- (i) The warranties specified herein do not apply to the following parts or conditions and cannot be relied upon in the situation whereby:
 - i) any Pilot Air product or part has been subject to misuse, negligence, accidental damage, improper or inadequate use, inadequate maintenance or improper storage or been operated under unusual conditions or continuously under excessive load;
 - ii) the defect has been caused by the use of non-genuine Pilot Air parts;
 - iii) the defect or deterioration was due to normal use, fair wear and tear and exposure, unless due to any defect in material or workmanship;
 - iv) work was undertaken on any Pilot Air product or part by an unauthorised Pilot Air agent;
 - v) the serial /model label has been removed from any Pilot Air product or part;
 - vi) normal maintenance items/parts including valves and piston rings
- (j) Warranty repairs on all 240 Volt and portable units shall be on a back to base basis that the Claimant is required to return the Product to the nominated warranty agent as advised by Pilot Air, provided that such costs are not significant;
- (k) The replacement or repair of any defective part or correction of operating faults under any warranty specified herein is to be made only after Pilot Air, or its authorised representative, have examined the unit to their satisfaction, with their decision being final.
- (l) In the circumstances where Pilot Air accepts or it is determined by Pilot Air that the claimant has a valid claim under this warranty, and subject to paragraph (m) below, Pilot Air will bear all of the claimant's reasonable and proximate expenses incurred as a result of claiming under this warranty. The claimant is to inform Pilot Air in writing to the address identified below within 21 days from when the claimant first makes a claim under this warranty of all such claims and expenses and provide it with copies of all receipts and invoices where relevant before any reimbursement is made by Pilot Air to the claimant. The claimant is responsible for all other costs of claiming under this warranty.

Warranty

- (m) Pilot Air will not be responsible for any courier, transport or freight related costs whatsoever associated with the return to it of any defective Product that have not first been approved by it. Pilot Air reserves the right to first inspect any defective Product and decide how, if at all, the defective Product is to be returned to it. Any unapproved courier, transport or freight related costs will be to the claimant's account.

Important Note:

If you acquire goods from Pilot Air as a consumer according to the Australian Consumer Law, our goods come with guarantees that cannot be excluded under the Australian Consumer Law. You are entitled to a replacement or refund for a major failure and for compensation for any other reasonably foreseeable loss or damage. You are also entitled to have the goods repaired or replaced if the goods fail to be of acceptable quality and the failure does not amount to a major failure.

Any rights a consumer may have under any warranty specified herein are in addition to other rights and remedies of a consumer under a law in relation to the goods to which these warranties relate. Nothing in this document shall exclude or modify any legal rights a customer may have under the Australian Consumer Law or otherwise which cannot be excluded or modified at law.

Contact details if you wish to make a claim under any warranty specified herein:

For more information or to make a claim under any warranty specified herein please telephone Pilot Air on (02) 9648 3099, email Pilot Air via our website: <http://www.pilotair.com.au> or write to Pilot Air at:

Pilot Air Compressors Pty Ltd 115 Beaconsfield Road
Silverwater NSW 2128