



PAC SERIES



PAC SERIES 4 / 5.5

User's Maintenance & Spare Parts Manual

Dear Customer,

Thank you for choosing Pilot Air.

In order to get the best performance out of this product, please read this manual carefully.

To avoid incorrect operation of the equipment and possible physical risk to the operator, please read and strictly follow the instructions contained in this manual.

Note, these instructions are in addition to the safety rules that apply in the country where the air compressor is installed.

Before packing for shipment, each machine undergoes a rigorous test to ensure the absence of any manufacturing faults and to demonstrate that the device can perform all the functions for which it has been designed.

This manual must be maintained available in any moment for future references and it has to be intended as inherent part of the relevant dryer.

Due to the continuous technical evolution, we reserve the right to introduce any necessary change without giving previous notice.

Should you experience any trouble, or for further information, please do not hesitate to contact us.

Best Regards,



PILOT AIR COMPRESSORS

<http://www.pilotair.com>

Phone: 1300 667 579

Email: service@pilotair.com.au / spares@pilotair.com.au

DECLARATION OF CONFORMITY

The following declaration is attached to the compressor in original copy.

All identification data: manufacturer, model, code and serial number are stamped on EC label. For any request for copies it is ESSENTIAL to provide ALL the data stamped on EC label.

I - Dichiaro sotto la sua esclusiva responsabilità, che il compressore d'aria qui di seguito descritto è conforme alle prescrizioni di sicurezza delle direttive: 2006/42/CE, 2006/95/CE, 2004/108/CE, 2009/105/CE.	GR - Dhlwnei, me apokleistika/ dikh/ thj euq/nh, o/ti o sumpiesthj ae/roj pou perigra/fetai paraka/tw antapokri/netai stj prodiagrafelj asfalei/aj twn odhgiwn 2006/42/EE, 2006/95/EE, 2004/ 108/EE, 2009/105/EE
GB - Declares under its sole responsibility that the air compressor described below complies with the safety requirements of directives: 2006/42/EC, 2006/95/EC, 2004/108/EC, 2009/105/EC	PL - oświadcza pod pełną własną odpowiedzialność, że opisana niżej sprężarka powietrzna odpowiada wymaganiom bezpieczeństwa zawartym w Dyrektywach 2006/42/EC, 2006/95/EC, 2004/108/EC, 2009/105/EC
F - Déclare sous son entière responsabilité que le compresseur d'air décrit ci-après est conforme aux prescriptions de sécurité des directives : 2006/42/CE, 2006/95/CE, 2004/108/CE, 2009/105/CE	CZ - prohlašuje s plnou odpovědností, že uvedený vzduchový kompresor vyhovuje bezpečnostním požadavkům směrnic: 2006/42/ES, 2006/95/ES, 2004/108/ES, 2009/105/ES
D - Erklärt unter ihrer alleinigen Verantwortung, daß der in Folge beschriebene Luftkompressor den Sicherheitsvorschriften der Richtlinien: 2006/42/EG, 2006/95/EG, 2004/108/EG, 2009/105/EG	SK - Zodpovedne vyhlasuje, že uvedený vzduchový kompresor zodpovedá bezpečnostným požiadavkám smerníc 2006/42/ES, 2006/95/ES, 2004/108/ES, 2009/105/ES
E - Declara bajo su exclusiva responsabilidad que el compresor de aire descrito a continuación responde a las prescripciones de seguridad de las directivas :2006/42/CE, 2006/95/CE, 2004/108/CE, 2009/105/CE	H - teljes felelősségének tudatában tanúsítja, hogy az alábbiakban jelmezett légkompresszor a 2006/42/EC(from 29/12/2009), 2006/95/EC, 2004/108/EC, 2009/105/ECE
NL - Verklaart onder zijn eigen verantwoordelijkheid dat de hieronder beschreven uchtcompressor in overeenstemming is met de veiligheidsvoorschriften van de richtlijnen: 2006/42/EG, 2006/95/EG, 2004/108/EG, 2009/105/EG	LT - Su visa atsakomybe pareiškia, kad žemiau aprašytas oro kompresorius atitinka saugumo direktyvą 2006/42/ES, 2006/95/ES, 2004/108/ES, 2009/105/ES
N - Erklærer under eget ansvar at luftkompressoren her beskrevet er i overensstemmelse med sikkerhedsforskrifterne i direktivene: 2006/42/EC, 2006/95/EC, 2004/108/EC, 2009/105/EC	LV - Apliecinā zem savas pilnīgas atbildības, ka apakšā aprakstītais gaisa kompresors atbilst direktīvu: 2006/42/EC, 2006/95/EC, 2004/108/EC, 2009/105/EC
S - Försäkrar under eget ansvar att den luftkompressor som beskrivs följande är i överensstämmelse med säkerhetsföreskrifterna i EU-direktiv: 2006/42/EG, 2006/95/EG, 2004/108/EG, 2009/105/EG	EST - Avaldab enda täieliku vastatusega, et edaspidi kirjeldatud õhukompressor vastav ohutuse nõudmistele direktiividele 2006/42/EC, 2006/95/EC, 2004/108/EC, 2009/105/EC
DK - Forsikrer på eget ansvar, at luftkompressoren, der beskrives nedenfor, er i overensstemmelse med sikkerhedsforskrifterne i direktivene: 2006/42/EC, 2006/95/EC, 2004/108/EC, 2009/105/EC	SLO - Na lastno odgovornost izjavlja, da je spodaj opisani zračni kompresor v skladu z varnostnimi predpisi, ki veljajo za stroje 2006/42/EU, 2006/95/EU, 2004/108/EU, 2009/105/EU
P - Declara sob a sua exclusiva responsabilidade que o compressor de ar descrito a seguir está em conformidade com as prescrições de segurança das directivas:2006/42/CE, 2006/95/CE, 2004/108/CE, 2009/105/CE	RO - Declara pe propria raspundere ca,compresorul de aer denumit in continuare,este in conformitate cu cerintele de securitate cuprinse in directivele: 2006/42/CE, 2006/95/CE, 2004/108/CE, 2009/105/CE
FI - vakuuttaa, että seuraavassa esitelty ilmakompressorin vastaa alla lueteltujen direktiivien turvallisuusvaatimuksia: 2006/42/EC, 2006/95/EC, 2004/108/EC, 2009/105/EC	RU - Заявляет под свою полную ответственность, что нижеописанный воздушный компрессор соответствует требованиям безопасности согласно директивам, 2006/42/EC, 2006/95/EC, 2004/108/EC, 2009/105/EC

INDEX

GB

1	Declaration of Conformity	3
2	General Information	5
3	Safety Indications	6
4	Installation	9
5	Technical Features	11
6	Controls and Settings	12
7	Alarms	14
8	Maintenance	16
9	Troubleshooting	19
10	Wiring Diagram	20
11	Warrant Terms and Conditions	22

GENERAL INFORMATION

OUTFIT

The following accessories are supplied with the compressor:

- User's Guide
- Anti-Vibration Elements
- Oil / Condensate Exhaust Tube

NOTE: Check that the above accessories are available. Once the goods have been delivered and accepted, no complaints are accepted.

CONDITION OF THE MACHINE WHEN SUPPLIED

Every compressor is shop tested and delivered ready to be installed and to be set at work.
Oiled used is **ROTENERGY PLUS**.

READ THIS PAGE CAREFULLY BEFORE PERFORMING ANY OPERATION ON THE COMPRESSOR

SAFETY INDICATIONS

GENERAL

- Rotary compressors are intended for heavy continuous industrial use. They are especially suitable for industrial applications requiring high air consumption for a long time.
- The compressor should be run and operated only in compliance with the indications given in this manual. Safely keep this manual in a known and easily reachable place for the whole working life of the compressor.
- A supervisor shall be appointed in the company, in which the compressor is installed. He/she shall be responsible for compressor inspections, adjustments and maintenance. Should a substitute be appointed for the supervisor, he/she shall carefully read the user's guide and all possible comment on service and maintenance carried out so far.

SYMBOLS USED IN THE MANUAL

Some symbols are used to highlight danger situations, give recommendations or information. These symbols are usually positioned next to the text, a figure or at the top of a page (in this case they refer to all subjects dealt with in that page).

Carefully read symbol meaning below:



CAUTION!

Important description on service, dangerous situation, safety, accident prevention recommendations and/or very important information.



POWER OFF!

All operations to be strictly carried out only after powering off the machine.



STOP MACHINE!

All operations to be strictly carried out only after stopping the machine.



SPECIALIZED PERSONNEL!

All operations to be strictly carried out only by specialized technician.

Safety Indications

READ THIS PAGE CAREFULLY BEFORE PERFORMING ANY OPERATION ON THE COMPRESSOR

SYMBOLS ON THE COMPRESSOR

The compressor has several labels to highlight possible danger and give recommendations on what to do during machine operation or in special situations.

Please comply with these indications.



Danger! Hot!



Danger! Electric shock!



Danger! Hot gas or harmful gas within working area



Danger! Pressurized container



Danger! Mechanical moving parts



Caution! Maintenance works in progress



Machine with automatic start-up



Prohibited! Do not open doors during compressor operation



Prohibited! Press emergency button for compressor immediate stop. Do not use line knife switch.



Prohibited! Do not use water on electric equipment to extinguish fire.



Compulsory! Read instructions for use carefully.

Safety Indications

READ THIS PAGE CAREFULLY BEFORE PERFORMING ANY OPERATION ON THE COMPRESSOR

WHAT TO DO:

- Make sure that mains voltage corresponds to the voltage indicated on CE plate and that cable of suitable cross-section are used for electric connections.
- Always check oil level before starting the compressor.
- Be familiar with emergency stop control and all other controls.
- Unplug the connector before any maintenance work, so to avoid accidental start. Ensure that all parts have been correctly reassembled after any maintenance work.
- Keep children and animals off the working area to avoid injuries caused by devices connected to the compressor. Ensure that temperature of the working environment ranges between +5 and + 45°C. The compressor should be installed and operated in a non-explosive environment.
- Leave at least 80 cm between the compressor and the wall. This prevents obstructing the air passage of the electric fan.
- Press the emergency button on the control panel only in case of actual need so as to avoid possible damages to people or the very compressor.
- When calling for technical assistance and/or advice, always mention model and serial number indicated on CE plate. Always follow the maintenance schedule specified in the user's guide.

WHAT NOT TO DO:

- Do not touch inner parts and pipes as they are very hot during compressor operation and stay hot for a certain time after compressor stops.
- Do not position inflammable or nylon objects or cloths close to and onto the compressor. Do not move the compressor when the tank is under pressure.
- Do not operate the compressor if the power cable is damaged or defective or if connection is unstable. Do not operate the compressor in wet or dusty environments. Never aim the air jet at people or animals.
- Do not allow unauthorized people to operate the compressor and give them all required instructions. Do not hit fans with blunt objects as they might break during compressor operation. Never operate the compressor without air filter.
- Do not tamper with safety and adjusting devices.
- Never operate the compressor when doors/panels are open or removed.

PRODUCT IDENTIFICATION

The compressor you have purchased has its own CE plate showing the following data:

- 1) Manufacturer's data
- 2) CE mark - year of manufacture
- 3) TYPE = name of the compressor CODE = compressor code
SERIAL NO. = serial number of the compressor You have purchased (to be always mentioned when calling for technical assistance)
- 4) max. operating pressure (bar and PSI) - compressor noise level in dB(A)
- 5) electric data: voltage (V/ph), frequency (Hz), absorption (A) - power (HP and kW), rotations per minute (Rpm).
- 6) other approvals

1	2
<input type="text"/>	CE <input type="text"/>
3	4
<input type="text"/>	<input type="text"/>
5	6
<input type="text"/>	<input type="text"/>
<input type="text"/>	<input type="text"/>

MACHINE DESCRIPTION

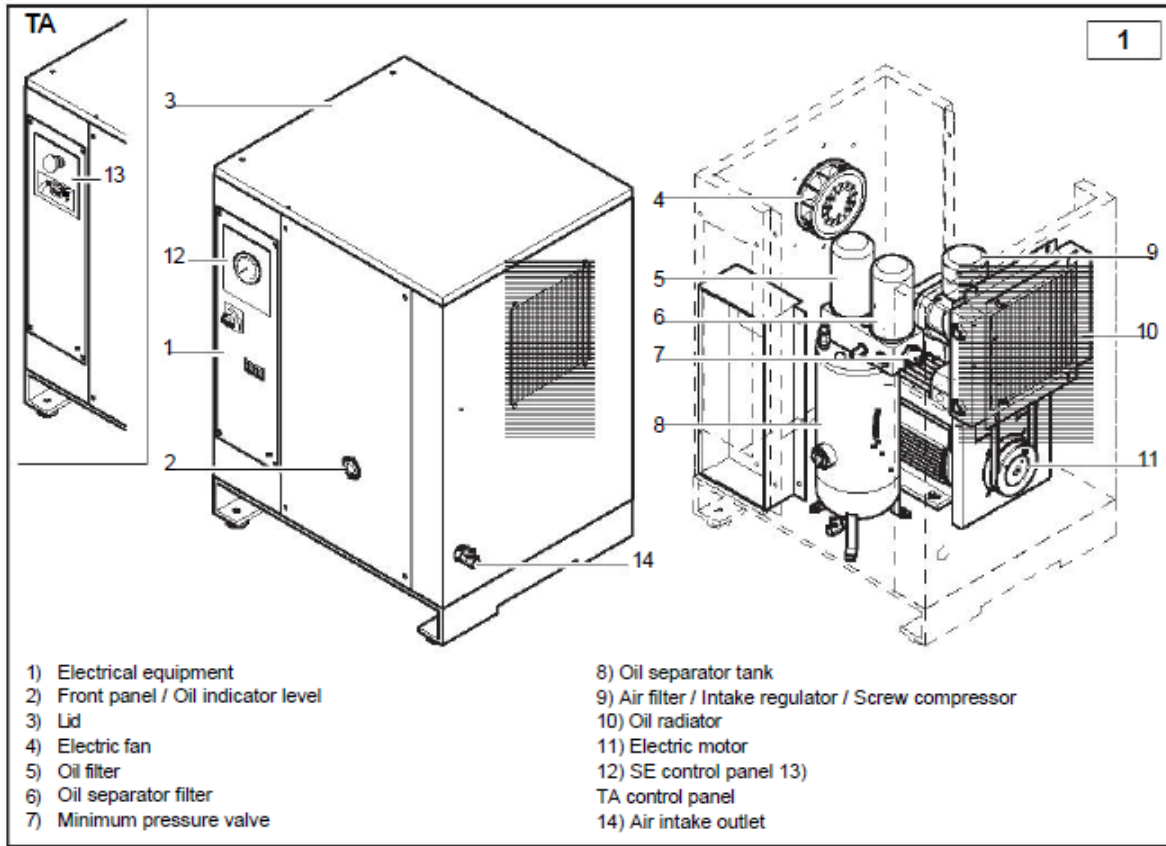

UNPACKING AND HANDLING THE MACHINE

- When delivered, compressor top is protected by cardboard packing.
- Wear suitable protective gloves and then cut outer straps and then remove cardboard from the top. Check the (outer) good condition of the machine before moving the compressor. Visually check that no parts are damaged. Also, ensure that all accessories are available.
- Lift the machine using a fork lift truck. Fit the anti-vibration elements into their proper seat and move the machine to the room chosen for its location with maximum care.
- Keep all packing materials at least for the warranty period for possible moving. In case of need, it will be safer for delivery to the technical assistance dept.
- Then, dispose of packing materials in compliance with current laws.

LOCATION (fig. 2)

The room chosen for the installation of the compressor should meet the following requirements and comply with what is specified in the current safety and accident prevention regulations:

- **low percentage** of fine dust,
- **proper room ventilation and size** that allow room temperature under 45°C. In the event of inadequate hot air discharge, fit the exhaust fans as high as possible.

Condensate should be collected either into a pit or a tank. The dimensions of the spaces are indicative only but it is advisable to follow them as closely as possible.

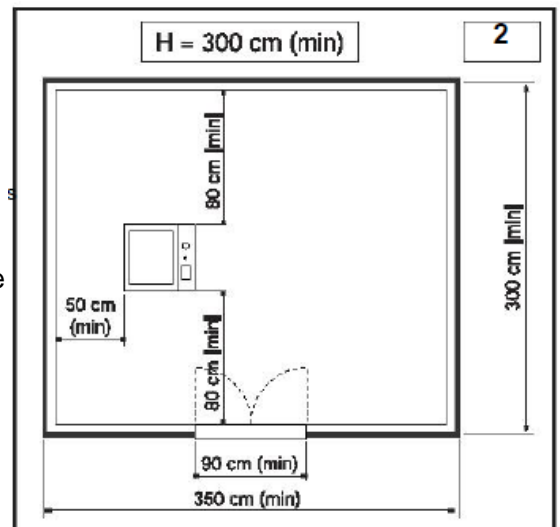



ELECTRICAL HOOK UP (Fig 3)

- The mains cable should have a cross-section suitable for the machine power and should include no. 3 phase wires, no. 1 neutral cable and no. 1 earth wire.
- Between the mains cable and the compressor control panel a fused switch near the point where the cables go into the machine **is absolutely necessary**. The switch should be at least at 1.7 m from the ground.
- The switch (A) should be easily reached by the operator. The cables should be of the approved type and installed with the following grade of protection: minimum IP44.

N.B. To determine the cables cross-section and the type of switch refer to the data reported on the technical table. Sizing according to "VDE 0100, Part 430 and 523", star-delta starter, 30° C ambient temperature and cable length lower than 50 meters.

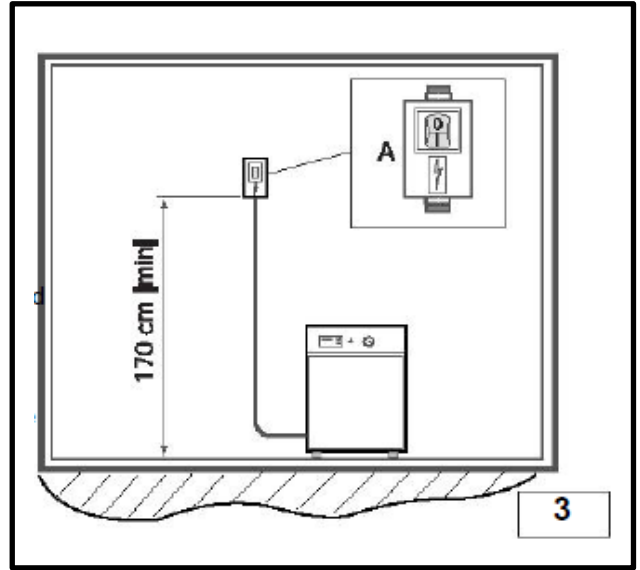

Electric connection					PAC 4	PAC 5.5
conductor min. section	mm ²				4G25	4G25
magnetic thermal switch	A				16	20
fuses	AgI				16	16

Technical Features



TECHNICAL CHARACTERISTICS		Hp				PAC 4			PAC 6.6		
Work pressure	bar g					8	10	13	8	10	13
	type										
Air outflow rate (according to ISO 1217 annex C)	l/min					680	486	360	720	660	486
Oil quantity	l					2.2			2.3		
	l										
	°C										
Heat carried	kJ/h					13880			13880		
Fan flow rate	m ³ /h										
Oil residuals in the air	mg/m ³					24					
Electric motor	type					BBB14					
Nominal input	kW					4			6,5		
Max input power from the mains	kW					6,2	6,1	6	8,5	8	8,6
Electric box protection class	IP					54			54		
Ambient temperature limit	°C					2 - 45					
Sound pressure (according to Pneuop/Cagi PN2CPTC2)	dB(A)					80			86		
ELECTRICAL DATA											
Voltage power supply	V/Ph					400/3					
Auxiliary voltage	V/Ph					24/1			24/1		
Current input at start up	A					24			30		
Max current input	A					8,7	8,6	8,4	10,2	0,6	1,2
Max. Absorbed current (vacuum)	kW					1,21			1,62		
Electric motor protection degree						56F					
Service factor						1,1					
PROTECTION DEVICES											
Oil circuit max temperature	°C					110					
Thermal motor relay calibration	A					62			88		
Safety Valve alibration	bar					14			14		
DIMENSIONS AND WEIGHT											
Length	mm					680					
Width	mm					480					
Height	mm					780					
Weight	kg					94			87		
Air outlet	Ø"					1/2"			1/2"		

CONTROL PANEL

Fig. 5

The compressor is equipped with an electronic control called "Easytronic II Micro" which manages all of the compressor functions.

1. START Key: Controls start-up of the compressor
2. RESET Key: Controls turning off of the compressor
3. "Function" Key: Allows movement from one display to the other
4. Display: Shows the information
5. Alarm Warning Lights: Turn on in case of alarm
6. Screw Warning Light: Turning on means that the compressor is loading.
7. Stand-by warning light: Turning on indicates the compressor is waiting
8. Emergency Shutdown Button: Pressing this button causes immediate stoppage of the compressor.
To be used only and exclusively in the event of real need.

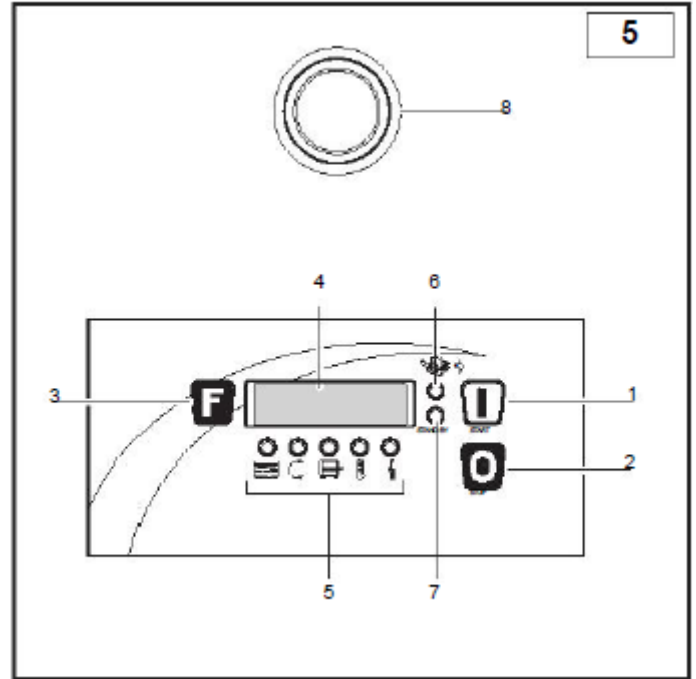

WORKING TIMES

- The compressor function is regulated by the electronic control unit, which measures the pressure by means of a pressure transducer and determines the stopping of the machine when the maximum pressure is reached (vacuum pressure) and it restarts when the pressure decreases to the minimum calibration level (load pressure).
- The machine stop is a delayed type that does not occur at exactly the same time as reaching maximum P value but after a certain time (vacuum time), during which no air is taken.
- The factory vacuum time is 75 seconds but check that the n° of switch on per hour DO NOT exceed the max advised n° of 10. If above 10, increase the "vacuum time", in order to avoid not necessary switch on and switch off cycles.

Controls and Settings

MODIFIABLE PARAMETERS

These settings apply exclusively to the models fitted with Easytronic II Micro power unit.

User Menu

With the compressor off, keep the "Function" key pressed for at least 5 seconds.

N°	Parameter	U.M	Min. value	Default value	Max value
U0	Set loadless pressure (*)	Bar	0.5	10.0	15.0
U1	Set loading pressure (**)	Bar	0	8.5	(Set P loadless) - 0.5
U2	Unit of measure (***)	Bar/Psi	0	1	1

- To select the parameter desired, use START (forward) and RESET (back) keys.
- Then press the FUNCTION key to show the value of the chosen parameter.
- To change the value, use START (to increase) and RESET keys (to decrease).
- Confirm the value set by pressing the FUNCTION key.
- The power unit returns to the main menu, and after 5 seconds without pressing any key it returns to the standard display.

(*) Set loadless pressure: indicates the value of pressure at which the compressor starts the loadless operating cycle.

(**) Set loading pressure: indicates the value of pressure at which the compressor starts compressing air again.

(***) 1=bar, 0=psi

Assistance menu

The settings below must be performed only by authorised technicians.

With the compressor off or in alarm status, keep the "FUNCTION" and "RESET" buttons pressed for at least 5 seconds, then a password will be requested.

N°	Parameter	U.M	Min. value	Default value	Max value
A0	Temperature to power fan	°C	0	80	150
A1	Time loadless	sec.	30	75	900
A2	Delay time in stoppage phase	sec	30	60	900
A3	Enable pressure sensor (*)		0	1	1
A4	Enable temperature sensor (*)		0	1	1
A5	Enable automatic start (*)		0	0	1
A6	Enable phase sequence (*)		0	1	1
A7	Expiry oil hours	hours	0	4000	65536
A8	Expiry oil filter hours	hours	0	4000	65536
A9	Expiry air filter hours	hours	0	2000	65536
A10	Expiry oil separator hours	hours	0	4000	65536
A11	Total hours (**)	hours	0	—	65536
A12	Loading hours (**)	hours	0	—	65536

(*) 1=enabled, 0=disabled

- To select the parameter desired use START(forward) and RESET keys (back).
- Then press the FUNCTION key to show the value of the chosen parameter.
- To change the value use START (to increase) and RESET keys (to decrease).
- Confirm the value set by pressing the FUNCTION key.
- The power unit returns to the main menu, and after 5 seconds without pressing any key it returns to the standard display.

Alarms

During normal operation of the compressor, the following signals can occur:

Alarm warning lights (rif.5, fig.5)



Water present in the separator tank. (Optional, not available in the standard configuration)
Blinking warning light = signal without compressor block
Fixed warning light = compressor block
Drain the condensate from the oil separator tanks (see chapter "Maintenance").



The warning light turns on to indicate a wrong electrical connection. The compressor blocks.
Check connection to the mains cable and to the terminals of the electrical panel of the compressor.



Oil temperature.
Blinking warning light = pre-alarm without compressor block
Fixed warning light = alarm with compressor block
Let the compressor cool down and check the oil level.



The maximum temperature of the motor has been exceeded. The compressor blocks. Let the motor cool down and check setting of thermal relay.



Indicates there has been a blackout. The compressor blocks.
With compressor stopped, press RESET to disable the alarm before restarting.

Alarm messages, the following alarms are shown on screen:

AL1	Faulty or broken temperature sensor with blockage of compressor. Replace sensor.
AL2	Faulty or broken pressure sensor with blockage of compressor. Replace sensor.
AL3	No phase or phase sequence transformer not operational with blockage of compressor. Check presence of phase and if necessary replace transformer. Maximum alarm pressure with blockage of compressor.
AL4	Contact an assistance centre to remove the cause of the problem. Fast rise in temperature with blockage of compressor.
AL5	Contact an assistance centre to remove the cause of the problem. The emergency button has been pressed. Reset the button to correct position.
AL6	

All alarms cause the compressor to block, which can be restarted only when the problem which has caused the blockage is resolved.

The alarm signal remains even after the problem has been solved, to disable it press the RESET button before restarting the compressor.

Maintenance signalling

The power unit also signals periodic maintenance operations, the internal counters decrease at each hour of loading of the compressor until zero is reached, at this point the maintenance signal will appear on the display:

CH1	Expiry of oil hours. Replace oil.
CH2	Expiry of oil filter hours. Replace oil filter
CH3	Expiry air filter hours Replace air filter.
CH4	Expiry of oil separator hours Replace oil separator filter.

If more signals are verified at the same time they are displayed in sequence.
Once the maintenance has been performed the internal counters must be reprogrammed.

Before starting the machine for the first time, **check that:**

- The mains voltage is the same as the voltage on the CE plate.
- The electric connections have been made using cables of proper cross-section.
- The (wall) main power switch has suitable fuses.
- The oil level is over the minimum level – top up with the same type of oil if necessary.

CONNECT THE TANK WITH A HOSE.

Only specialised technicians can start the compressor for the first time.

See Fig. 5

The **turning on procedure** starts by pressing the START key (1).

The Stand-by led (7) blinks and after a few seconds the presence of the phases and their correct sequence is checked, if the compressor blocks and the warning light turns on the phase sequence device has intervened, press the RESET key (2) and bring the wall switch to OFF position.

Open the electric compartment and invert the position of two phases in the power terminal box. Close the electrical compartment and restart.



The start-up procedure is repeated: the Screw led (6) blinks and after a few seconds it becomes fixed, the load phase starts until the "set loadless pressure" value is reached.

The Screw led (6) blinks again and the loadless operation phase begins.

If at the end of the loadless operation (default 75 sec.) the pressure has not fallen below the "set load pressure" value the compressor stops and the Stand-by led turns on (7); otherwise upon reaching the "set load pressure" value the compressor restarts the loading phase and the Screw led turns on in fixed mode (6).

During normal function, press the Function key (3). The following information will be displayed:

- Pressure
- Temperature
- Total hours of operation (with compressor on)
- Hours of operation loaded (with compressor in load phase).

By pressing the RESET key (2) the **turn off procedure** starts, the Screw led (6) blinks and the compressor enters the loadless operation mode for the time set by the parameter "delayed stop time" (default 60 sec.). At the end of the cycle the compressor stops.

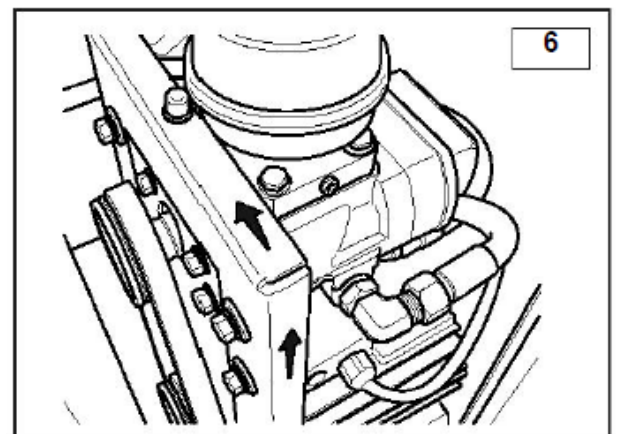
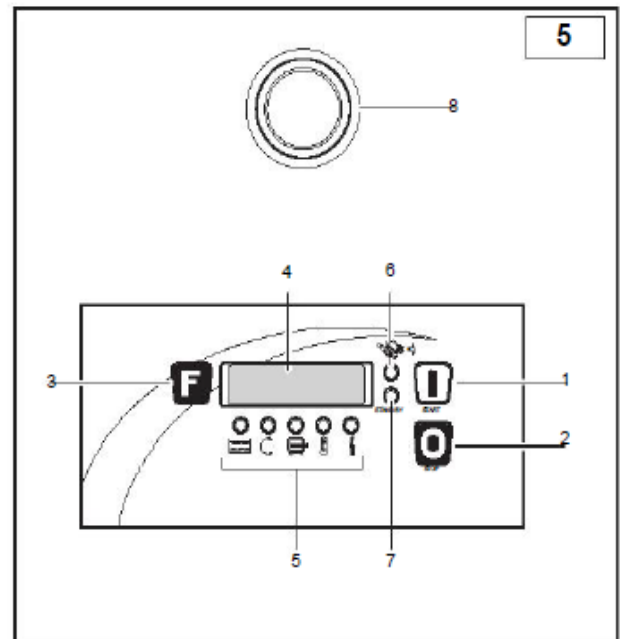

Maintenance

- Correct maintenance is crucial to achieve maximum efficiency of your compressor, and to lengthen its operating life.
- It is also important to comply with the maintenance intervals recommended, but it must be remembered that such intervals are suggested by the manufacturer in the event that the environmental conditions of use of the compressor are optimal (see "Installation" chapter).
- The maintenance intervals can therefore be reduced depending on the environmental conditions in which the compressor operates.
- The oil used is RotEnergy Plus, the use of a different oil does not guarantee perfect efficiency and compliance with the maintenance intervals.
- The following pages describe the routine maintenance operations which can be performed by the person in charge of the compressor, the non-routine maintenance operations must instead be performed by an authorised technical assistance centre.



Maintenance table

TYPE OF MAINTENANCE	MAINTENANCE SCHEDULE	
	work hours	o at least
ORDINARY MAINTENANCE		
Condensation release	-	Drain daily
Oil level check and refill	500	once per month
Clean filtering element	500	-
Check the transmission belt	500	-
Check blockage and clean radiator	1000	once a year
Replace the filtering element	1000	once a year
Oil filter substitution	1000	once a year
Replace separator element	4000	once a year
Total oil change	1000	once a year
EXTRAORDINARY MAINTENANCE		
Substitute the transmission belt	6000	
Suction valve overhaul	8000	
Minimum pressure valve overhaul	8000	
Solenoid-valve substitution	12000	
Substitute the flexible tube	12000	
Substitute the electric motor bearings	12000	
Screw compressor overhaul	20000	

If the hourly limit is not reached, the maintenance operations highlighted in bold must be performed at least 1 time a year.

- To verify correct machine operation, perform the following checks after the first 100 hours of work: 1) Check the oil level: top up with the same type of oil if necessary. 2) Check for proper screw tightening: in particular the power electric connection screws. 3) Visually check that all fittings seal properly. 4) Check the belt tension and if necessary, reset it. 5) Check the hours of work and the type of service selected 6) Check room temperature.

BEFORE MAINTAINING THE MACHINE ALWAYS PERFORM THE FOLLOWING:

- √ Press the machine automatic stop button (do not use the emergency button).
- √ Power the machine off by means of the wall outer switch.
- √ Close the line cock.
- √ Make sure that no compressed air is inside the oil separator tank.
- √ Remove fairing and/ or panels.

DRAIN CONDENSATE

The oil/air mixture cooling is set at a higher temperature with respect to the dew point of the air (under standard operating conditions of the compressor). However, the condensate in the oil cannot be fully removed.

Blow off compressed air through cock B and then close it as soon as oil begins to flow out instead of water. Check the oil level and top up if necessary

CONDENSATE IS A POLLUTING MIXTURE! It must not be let into the sewage.

OIL CHECK AND TOP UP IF NECESSARY

(Fig.7)

With the compressor off, check the oil level by means of the warning indicator positioned on the front panel 2.

If the level is under the minimum, remove the front panel and refill through hole A. Quantity of oil for refilling from the min to the max level = 0.25 litres.

Use ONLY Pilot Air RS-68 oil.

CLEANING/REPLACING THE FILTERING ELEMENT (Fig.8)

With the compressor stopped, remove the lid and carefully clean the filtering element D using compressed air from the inside towards the outside. Check, against the light, for the presence of possible tears and if necessary, replace it.

The filtering element and the lid should be mounted with care, so that no dust can enter the compression unit.

Never allow the compressor to function without the filtering element.

Replace the filtering element D. Alarm signal CH3

CLEANING THE RADIATOR

It is recommended that in case of over temperature anomalies and however, at least once a year that the radiator is cleaned.

Proceed as follows:

position a sheet of protective plastic under the radiant pack; spray (with a washing + detergent gun) from inside towards the outside.

- check that the air flows correctly by means of the radiator.

REPLACING THE OIL FILTER (Fig.9)

With the compressor stopped, remove the lid and the front panel. Alarm signal CH2

At each change replace also the oil filter E, unscrew the old filter and replace it. Always apply some oil on the edge of the filter and on the seal before refitting manually the filter.

REPLACING THE SEPARATOR FILTER (Fig.9)

With the compressor stopped, remove the lid and the front panel. ALARM SIGNAL CH4

The oil separator filter D cannot be cleaned, but must be replaced.

- Unscrew filter manually (or if necessary use an appropriate filter tool) turning it anticlockwise.
- After having slightly greased the oil separator filter seal and O-ring, fit the new filter by turning clockwise.

REPLACING THE OIL (Fig.7)

When the compressor is hot - above 70 °C, replace the oil. Alarm signal CH1

- Remove the front panel
- Connect the drain hose provided to cock B located at the base of the separator tank.
- Unscrew the plug from hole A, open the cock and allow the oil to drain in to a container until draining is complete.

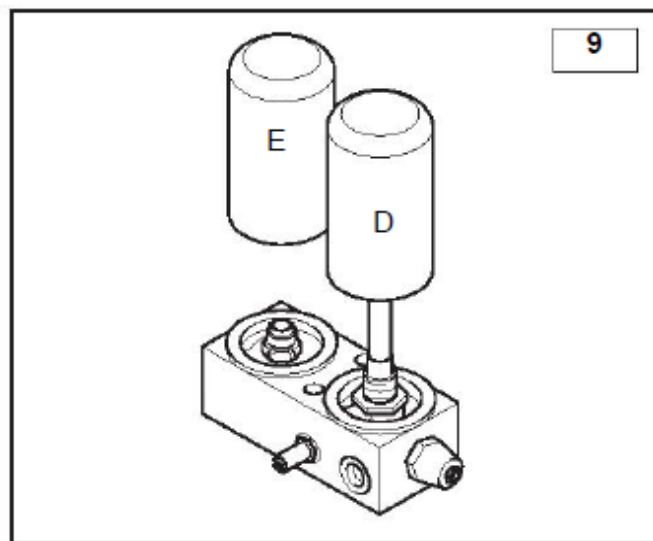
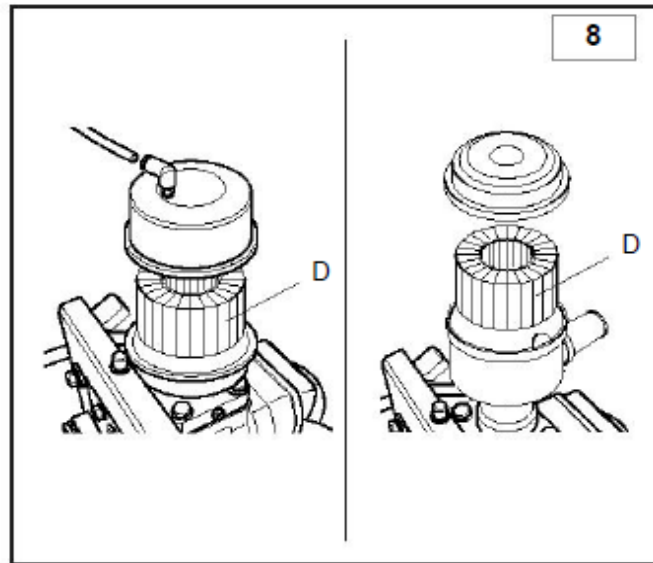
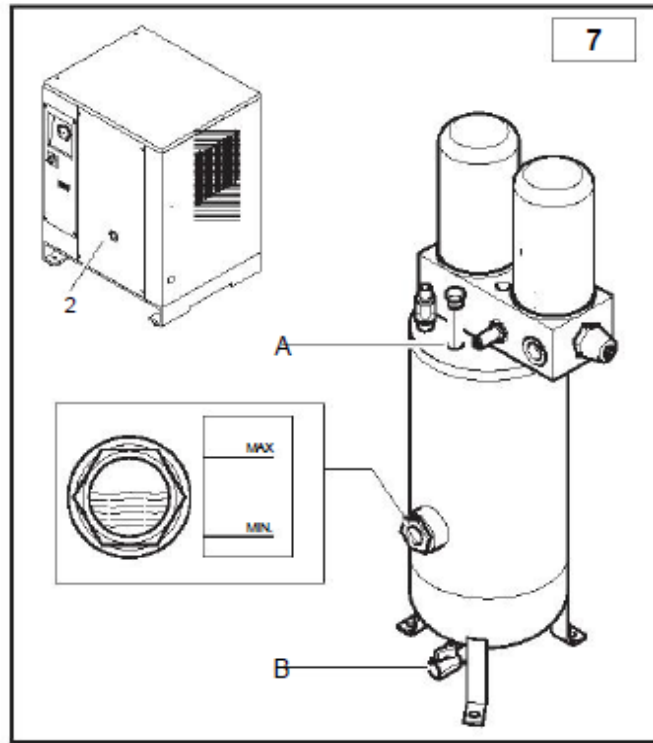

- Close cock B and withdraw the hose.
 - Refill with new oil using hole A (quantity for complete refilling: 2.2 litres) and refit the plug.
 - Start up the compressor and allow to function for 5 minutes, and then shut it down. Discharge all of the air and wait 5 minutes before controlling the oil level. Top up, if necessary.
- THE EXHAUSTED OIL IS HIGHLY POLLUTANT!** For its disposal comply with the current laws on environmental protection.
- The first equipment oil is: RotEnergy Plus.
- In the case of changing the type of oil, operate only for the complete replacement. **NEVER MIX DIFFERENT TYPES OF OIL.**
- In this case, change also the oil filter and the separator filter.

CHECKING THE TRANSMISSION BELT TENSION (Fig.10)

When the compressor is stopped, remove the rear panel and check the belt tension.

Use a suitable measuring instrument that determines with precision the belt tension degree by means of a frequency measuring device in order to perform this control.

Operate as follows:

- Place the microphone of the measuring instrument near to the belt (about half way) and hit the belt with a wrench.

• Read the value detected by the instrument and if different from the values indicated in the table (fig.10A), adjust the tension:

Value higher = belt too tight Value lower = belt too loose

Adjust by loosening the four bolts and adjust the tension with screw C2. After adjusting, tighten the bolts C1.

Check the frequency value again and if necessary, repeat the operation.

Z	08 BAR	110 Hz
Z	10 BAR	
Z	13 BAR	
S	08 BAR	
E	10 BAR	105 Hz
E	13 BAR	
A	08 BAR	
A	10 BAR	95 Hz
A	08 BAR	
A	10 BAR	90 Hz
3M	10 BAR	



REPLACING THE TRANSMISSION BELT (Fig.10)

When the compressor is stopped, remove the rear panel. Loosen the four bolts C1 and act on screw C2 loosening belt C until completely loose.

Remove the belt and replace it with a new one.

After replacing, check the belt tension as described previously.

REPLACING THE MINIMUM VALVE (Fig.11)

Replace the seals highlighted with the letter F.

REPLACING THE FLEXIBLE HOSES

It is recommended that they are replaced when changing the oil. Loosen the hose fittings, replace them and tighten with force the fittings. Continue with the final phases of the oil changing procedure.

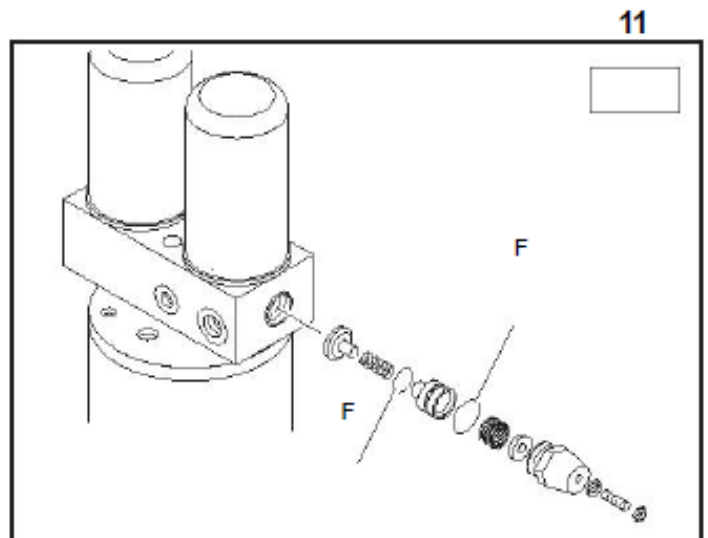

Troubleshooting



Problem	Cause	Remedy
Motor stopped (thermal relay operation signal)	Voltage too low	Check voltage, press Reset and then restart.
	Overtemperature	Check motor absorption and relay setting. In case of regular absorption press Reset and restart.
	Fan motor overtemperature	Check fan motor and clixon condition
Oil consumption high	Drainage faulty	Check oil drain hose and check valve
	Oil level too high	Check oil level and drain some, if necessary
	Oil separator filter broken	Replace oil separator filter
	Oil separator filter seal leaking	Replace oil separator nipple seals
Intake filter leaks oil	Intake regulator stays open	Check regulator and solenoid valve
Safety valve opening	Pressure too high	Check the pressure settings.
	Intake regulator does not close at the end of the cycle	Check regulator and solenoid valve
	Oil separator filter clogged	Replace oil separator filter
Sensor for compressor temperature triggered	Room temperature too high	Improve ventilation
	Radiator clogged	Clean radiator with solvent
	Oil level too low	Top up oil
	Cooling fan does not start	Check the electric fan motor.
Compressor performance low	Air filter dirty or clogged	Clean or replace filter
Compressor does not compress air while running	Regulator closed. It cannot open because dirty.	Remove intake filter and check for proper manual opening. Remove and clean, if necessary.
	Regulator closed. It cannot open because no command is received.	Check for signal on solenoid valve. Replace damaged part, if any.
Compressor compresses air over max. pressure value	Regulator open. It cannot open because dirty.	Remove and clean regulator
	Regulator open. It cannot open because no command is received.	Check for signal availability between pressure switch and solenoid valve. Replace damaged part, if any.
Compressor does not start	Oil separator filter clogged	Replace oil separator filter
	Min. pressure valve does not close perfectly	Remove the valve, clean and replace seal, if necessary
Compressor hardly starts	Voltage too low	Check mains voltage
	Tube leaking	Tighten fittings

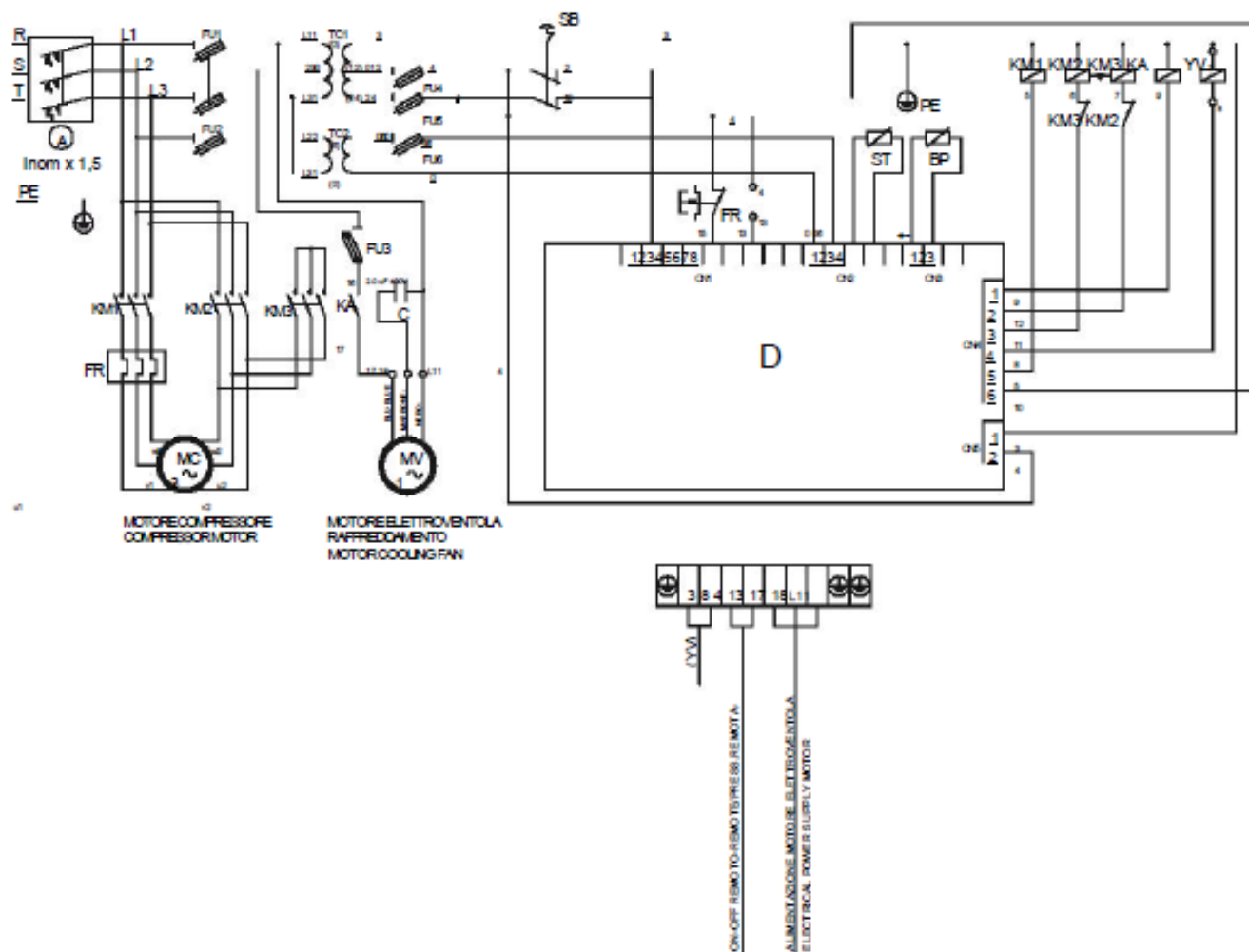

N.B.

1) Sez. ausiliari = 1mmq

2) (*) = 400V AC3

Rif/Ref	Denominazione/Denomination	HP5	
		230V	400V
TC1	Trasformatore/Transformer Pr 0/230/400 Sec 0/12/24		
TC2	Trasformatore/Transformer Pr 0/230/400 Sec 0/6		
SB	Pulsante di emergenza/Emergency Button + n. 2 NC 230V 10°		
FU1	Fusibili ceramici/Ceramic Fuse 10.3 x 38 GF 4A 500V		
FU2.FU3	Fusibili ceramici/Ceramic Fuse 10.3 x 38 GF 1A 500V		
FU4.FU5	Fusibili ceramici/Ceramic Fuse 10.3 x 38 GF 2A 500V		
FU6	Fusibile ceramico/Ceramic Fuse 10.3 x38 GF 500mA 500V		
KM1	Contattore linea-Line Contactor bob. 24 V 50/60 Hz	5,5 KW(*)	3 KW(*)
KM2	Contattore triangolo-Triangle Contactor bob. 24 V 50/60 Hz	5,5 KW(*)	3 KW(*)
KM3	Contattore stella-Star Contactor bob. 24 V 50/60 Hz	4 KW(*)	3 KW(*)
KA	Rele' ausiliario-Auxiliary Relay 2 contatti bob. 24Vac		
FR	Rele' termico-Thermal Relay reset MAN/AUT - 1L+1R	(7-10)	(4,5-6,3)
YV	Elettrovalvola-Solenoid Valve 24 VAC 50/60 Hz 8VA		
BP	Trasduttore di pressione-Pressure Transducer 0-16 Bar 4-20mA		
D	Controllore elettronico-Electronic controller 12VAC		
ST	Sonda termica-Temperature Probe per controllore		
MV	Motore E.V. raffreddamento-Motor cooling fan 230/1/50-60 Hz	70W	70W
	Sez. cavo motore-Section Cable Motor (mmq)	7G1,5	7G1,5

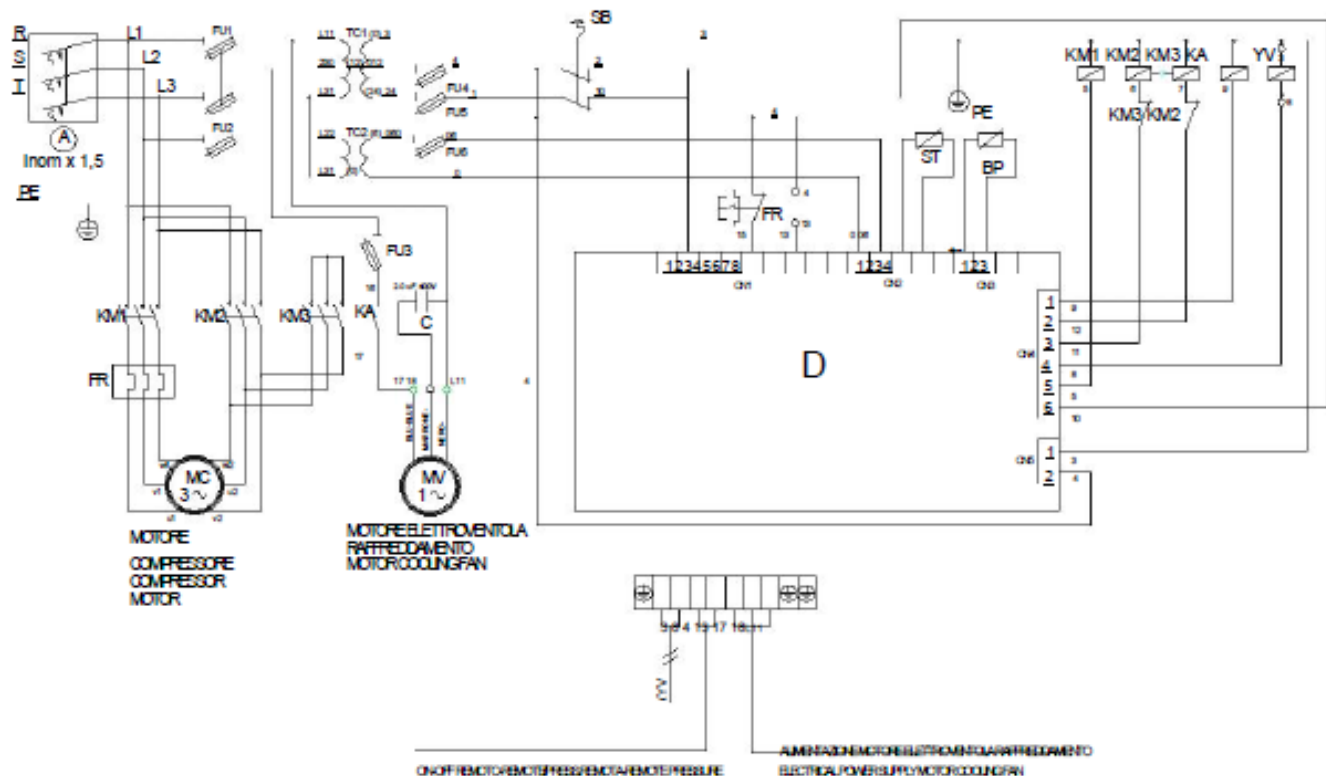

N.B.

1) Sez. ausiliari = 1mmq

2) (*) = 400V AC3

Rif./Ref.	Denominazione/Denomination	HP7	
		230V	400V
TC1	Trasformatore/Transformer Pr.0/230/400 Sec.0/12/24		
TC2	Trasformatore/Transformer Pr.0/230/400 Sec.0/8		
SB	Pulsante di emergenza/Emergency Button + n.2 NC 230V 10°		
FU1	Fusibili ceramici/Ceramic Fuse 10.3 x 38 GF 4A 500V		
FU2.FU3	Fusibili ceramici/Ceramic Fuse 10.3 x 38 GF 1A 500V		
FU4.FU5	Fusibili ceramici/Ceramic Fuse 10.3 x 38 GF 2A 500V		
FU8	Fusibile ceramico/Ceramic Fuse 10.3 x38 GF 500mA 500V		
KM1	Contattore linea-Line Contactor bob.24 V 50/60 Hz	7,5 KW(*)	4 KW(*)
KM2	Contattore triangolo-Triangle Contactor bob.24 V 50/60 Hz	7,5 KW(*)	4 KW(*)
KM3	Contattore stella-Star Contactor bob.24 V 50/60 Hz	5,5 KW(*)	4 KW(*)
KA	Rele' ausiliario-Auxiliary Relay 2 contatti bob. 24Vac		
FR	Rele' termico-Termal Relay reset MAN/AUT - 1L+1R	(9-12,5)	(5,5-8)
YV	Elettrovalvola-Solenoid Valve 24 VAC 50/60 Hz 8VA		
BP	Trasduttore di pressione-Pressure Transducer 0-16 Bar 4-20mA		
D	Controllore elettronico-Electronic controller 12VAC		
ST	Sonda termica-Temperature Probe per controllore		
MV	Motore E.V.raffreddamento-Motor cooling fan 230/1/50-60 Hz	70W	70W
	Sez. cavo motore-Section Cable Motor (mmq)	7G1,5	7G1,5

Warranty

Pilot Air Compressors Pty Ltd **manufactured goods - 1 Year Warranty and 3 Year Warranty (where applicable)**

(DATE)

Pilot Air Compressors Pty Ltd (**Pilot Air**) warrants to the first purchaser of goods (manufactured by it) (Product) from Pilot Air and the last purchaser prior to installation that, subject to compliance with the Conditions of Warranties below that:

1. For a period of 12 months from the date of purchase, the Product will be free from defects due to defective factory workmanship or materials; and
2. For a period of 12 months from the date of purchase that Pilot Air branded accessories supplied by Pilot Air will be free from defects due to defective factory workmanship or materials.
3. The compressor pump only (and excluding all other components of the unit) in the following units:
 - a. TM Series Units
 - b. Classic K Series Units
 - c. Petrol Industrial Series Units
 - d. Three Phase Industrial Series Units

will be free from defects due to defective factory workmanship or materials for a period of 3 years from the date of purchase.

4. The 'DCR', 'PAC' and 'FP' Series of Rotary Screw type compressors will be free from defects due to defective factory workmanship or materials for 3,000 working hours in the first 12 months from the date of purchase. This warranty is extended to a period of 2 years for the air end of the DCR PAC and FP Series Compressors.
5. Where compressors are powered with either petrol or diesel engines, the engine only is subject to the warranty provided by the manufacturer of the engine.
6. Non-Pilot Air accessories (meaning accessories which are not Pilot Air manufactured and branded) which are supplied by Pilot Air are not covered by this warranty. Purchasers are referred to the individual manufacturer's warranty. Purchasers can request a copy of the applicable warranties by contacting Pilot Air using the contact details below.

Warranty

Conditions of Warranties

The warranties specified herein are subject to the following conditions:

- (a) Pilot Air will not be liable for a breach of any of its warranties unless the Claimant provides proof of purchase of the Product and makes a written claim to Pilot Air at the address set out below, either within 30 days after the defect would have become reasonably apparent, or if the defect was reasonably apparent prior to installation, then the claim must be made prior to installation;
- (b) The warranties are not transferable;
- (c) The Product must be installed, operated, maintained and serviced strictly in accordance with the relevant Pilot Air literature current at the time of installation and must be installed in conjunction with the components or products specified in the Pilot Air literature. To obtain copies of such literature go to www.pilotair.com.au or telephone Pilot Air on (02) 9648 3099;
- (d) If the claimant chooses to rely upon any warranty specified herein the claimant's sole remedy under the warranty for breach of the warranty is (at Pilot Air's option) that Pilot Air will either supply replacement Product, rectify the affected Product or pay for the cost of the replacement or rectification of the affected product;
- (e) In the circumstances where the guarantees under the Australian Consumer Law do not apply in respect to the purchase of its Products, Pilot Air will not be liable for any losses or damages (whether direct or indirect) including property damage or personal injury, consequential loss, economic loss or loss of profits, arising in contract or negligence or howsoever arising. Without limiting the foregoing, Pilot Air will not be liable for any claims, damages or defects arising from misuse of the Product, inadequate maintenance and storage of the Product, repairs rendered necessary or arising from the use of non-genuine Pilot Air parts in the product, normal wear and tear maintenance of the Product, deterioration of any part of the Product due to normal wear and tear, work performed on the Product other than by an authorised Pilot Air service technician or their agent, use of the Product for any purpose other than which it was intended to be used, use of the Product after essential parts and accessories have been removed, operating the Product continuously under excessive load, and if the serial/model label has been removed or obscured on the Product;
- (f) In circumstances where the guarantees under the Australian Consumer Law do not apply in respect to the purchase of its Product/s: all warranties, conditions, liabilities and obligations other than those specified herein are excluded to the fullest extent allowed by law.
- (g) Parts repaired or replaced under any warranty specified herein are warranted only for the remaining period of the original warranty period.

Warranty

- (h) All defective parts that are the subject of a claim under any warranty specified herein become the property of Pilot Air.
- (i) The warranties specified herein do not apply to the following parts or conditions and cannot be relied upon in the situation whereby:
 - i) any Pilot Air product or part has been subject to misuse, negligence, accidental damage, improper or inadequate use, inadequate maintenance or improper storage or been operated under unusual conditions or continuously under excessive load;
 - ii) the defect has been caused by the use of non-genuine Pilot Air parts;
 - iii) the defect or deterioration was due to normal use, fair wear and tear and exposure, unless due to any defect in material or workmanship;
 - iv) work was undertaken on any Pilot Air product or part by an unauthorised Pilot Air agent;
 - v) the serial /model label has been removed from any Pilot Air product or part;
 - vi) normal maintenance items/parts including valves and piston rings
- (j) Warranty repairs on all 240 Volt and portable units shall be on a back to base basis that the Claimant is required to return the Product to the nominated warranty agent as advised by Pilot Air, provided that such costs are not significant;
- (k) The replacement or repair of any defective part or correction of operating faults under any warranty specified herein is to be made only after Pilot Air, or its authorised representative, have examined the unit to their satisfaction, with their decision being final.
- (l) In the circumstances where Pilot Air accepts or it is determined by Pilot Air that the claimant has a valid claim under this warranty, and subject to paragraph (m) below, Pilot Air will bear all of the claimant's reasonable and proximate expenses incurred as a result of claiming under this warranty. The claimant is to inform Pilot Air in writing to the address identified below within 21 days from when the claimant first makes a claim under this warranty of all such claims and expenses and provide it with copies of all receipts and invoices where relevant before any reimbursement is made by Pilot Air to the claimant. The claimant is responsible for all other costs of claiming under this warranty.
- (m) Pilot Air will not be responsible for any courier, transport or freight related costs whatsoever associated with the return to it of any defective Product that have not first been approved by it. Pilot Air reserves the right to first inspect any defective Product and decide how, if at all, the defective Product is to be returned to it. Any unapproved courier, transport or freight related costs will be to the claimant's account.

Warranty

Important Note:

If you acquire goods from Pilot Air as a consumer according to the Australian Consumer Law, our goods come with guarantees that cannot be excluded under the Australian Consumer Law. You are entitled to a replacement or refund for a major failure and for compensation for any other reasonably foreseeable loss or damage. You are also entitled to have the goods repaired or replaced if the goods fail to be of acceptable quality and the failure does not amount to a major failure.

Any rights a consumer may have under any warranty specified herein are in addition to other rights and remedies of a consumer under a law in relation to the goods to which these warranties relate. Nothing in this document shall exclude or modify any legal rights a customer may have under the Australian Consumer Law or otherwise which cannot be excluded or modified at law.

Contact details if you wish to make a claim under any warranty specified herein:

For more information or to make a claim under any warranty specified herein please telephone Pilot Air on (02) 9648 3099, email Pilot Air via our website: <http://www.pilotair.com.au> or write to Pilot Air at:

Pilot Air Compressors Pty Ltd 115 Beaconsfield Road
Silverwater NSW 2128