

Pilot OFP5.5SI Oil Free Industrial



USER MANUAL

OFP Silent Series Reciprocating Compressors



PH 1300 667 579

Spares@pilotair.com.au;Sales@pilotair.com.au

SAFETY



Pressure vessels (air receivers) are a type of plant, and as such, MAY be required to be registered with the relevant statutory authority in your state. Regulations regarding plant registration vary from state to state. Check with your relevant government authority about plant registration.

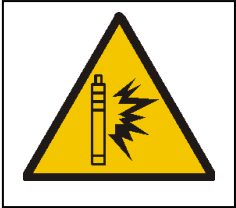

Compressed air can be dangerous. Never point compressed air tools or equipment towards another person.

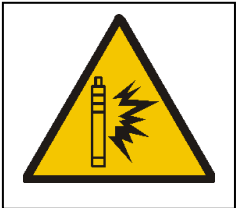

After use, drain all residual air pressure or engage outlet tap to prevent accidental discharge.



Keep clear of compressor pump during and after operation. Heat build up in the pump may cause burns to unwary.



Never operate the unit without factory fitted belt guard (belt drive models) or pump shroud (direct drive models).

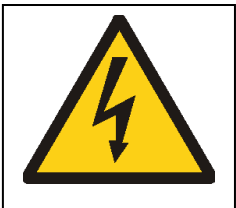

Never operate the unit with damaged or exposed electrical wiring.



Do not alter, adjust or remove any components on the unit without technical support from Pilot Air or an authorised Pilot Air agent

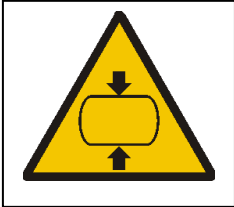

Whenever transporting an air compressor, ensure all air is drained from the air receiver. There should be NO residual air pressure in the air receiver.

SPECIFICATION CHART

MODEL	F.A.D.		Motor Size		Max. Pressure		Noise level	Dimensions (mm)			Weight
	L/min	CFM	KW	HP	KPA	PSI	D(B)A	L	W	H	KG
OFP2.2SI/240V	285	10.1	2.2 (240v)	3 (240v)	800	116	60	820	660	1090	195
OFP2.2SI	285	10.1	2.2	3	800	116	60	820	660	1090	195
OFP4SI	485	17.1	4	5.5	800	116	68	850	730	1060	210
OFP5.5SI	730	25.8	5.5	7.5	800	116	67	930	750	1360	315
OFP7.5SI	885	31.2	7.5	10	800	116	67	930	750	1380	330
OFP11SI	1320	46.6	11	15	800	116	75	1000	970	1270	365

INSTALLATION

LOCATION

- **An indoor installation is desirable with the seating ground able to bear the weight of the Air Compressor.**
- **Clean, well ventilated and free from corrosive or explosive vapor areas.**
- **Ensure a sufficient space around the compressor for the convenience of cooling and maintenance.**
- **Ensure the floor is levelled and of sufficient strength with adequate access for maintenance.**
- **Free space above the unit →Minimum of 1.5 M clearance.**
- **Free space on each side →Minimum of 1 M clearance.**
- **Place the unit on a flat surface.**

PRECAUTIONS BEFORE OPERATION

- **The compressor should be operated under the supervision of an authorized person.**
- **Never remove or modify the safety devices originally mounted on the Unit.**
- **Never remove the covers while this unit is in operation**
- **Make sure the voltage and frequency of the power source are correct.**
- **All maintenance works have to be executed by authorized person.**
- **Never operate the compressor at higher discharge pressure than those specified on the compressor nameplate pressure specification.**
- **Care needs to be exercised and the operation of the unit needs to be monitored in ambient conditions of 40 degrees or more.**

COMMISSIONING AND OPERATION

When commissioning a new compressor or re-commissioning a compressor which has been out of service, the following operation recommendations should be followed. (The operator should have experience and be qualified.)

1. COMMISSIONING

A. PRIMARY CHECKS:

- (1) Confirm that all the pipe and wire connections have been firmly connected, and the main power should be turned off.**
- (2) Make sure all the electrical connections are correct.**
- (2a) Ensure a qualified electrician is used to connect the compressor.**
- (3) Check the belts for tightness and adjust if required.**
- (4) Remove the RED FIXED PLATE.**
- (5) Open the Stop Valve and switch on the main power.**

B. CHECK BEFORE RUNNING

- (1) Confirm that the main Power Source and Earth have been connected well and the 3-phase voltage is correct.**
- (2) Press the START button and check rotation of Air end. The correct rotation is CCW looking from Air end pulley side (Follow the arrow label). If rotation is correct, go to next process. If the Air end rotates in the wrong direction, STOP immediately and exchange any two cables of power source.**

ATTENTION:

Incorrect rotation will result in serious damage to the air end.

C. CHECK WHILE RUNNING:

- (1) Switch power ON, press START.**
- (2) Check for strange noises or excess vibration.**
- (3) Ensure pressure is rising. If pressure does not rise, turn the unit off, check the Pressure Gauge, rotation of Air end and pressure pipe.**
- (4) If the unit is running in normal status, close all the covers.**

OPERATION

A. START

- (1) Switch the power on. Check the Power Indicator is on.**
- (2) Open the Stop Valve and push the START button. Confirm pressure is rising at correct working pressure.**

ATTENTION: If the compressor has not been run for a long period, ensure you follow Commissioning Instructions above before operating machine.

B. PRESSURE INDICATOR :

- (1) When discharge pressure reaches the upper limit of Pressure Switch, the compressor stops and the Pressure Indicator is on.**
- (2) When discharge pressure reaches the lower limit of Pressure Switch, the compressor starts and the Pressure Indicator is off.**

C. SHUT-DOWN

- (1) Push the STOP button to stop the compressor.**
- (2) In emergency situation, push the EMERGENCY STOP button.**

ATTENTION: Before restarting the unit ensure all faults have been rectified. Turn the EMERGENCY STOP 45° clockwise and then push the RESET button. Do not use EMERGENCY STOP in normal use or the equipment may be damaged.

D. RESET

Should the unit shut down either automatically or by use of the Emergency Stop button, ensure all faults are rectified before using the RESET button.

ATTENTION: All compressor parts and pipes will be very hot. Do not touch without protection as serious injury can occur.

MAINTENANCE PRECAUTIONS

- **All maintenance works are to be executed by authorized person.**
- **Always use spare parts supplied by the original factory for replacement**
- **Before commencing any maintenance, follow the procedure below**
 - **Switch the Main Power Breaker to “ OFF” position, and remove the fuse inside the control cabinet to disconnect the electric power to the control system.**
 - **Shut off the Stop Valve on the Air-outlet piping.**
 - **Release all the compressed air inside the Compressor unit and make sure the Pressure Gauge reading is “ZERO”.**

- **Only use the specified lubricants as specified by PilotAir.**
- **Ensure all oil sludge and dirt is removed before commencing maintenance.**
- **Make sure to follow the instructions mentioned in this manual and all the relative components and safety devices are operational.**
- **All the pressure gauges have to be inspected periodically. Replace them with new ones when the readings become irregular.**
- **Inspect all safety devices periodically and maintain inspection records**
- **Always keep the inner parts of the compressor unit clean to prevent from any foreign material or moisture flying into the inside of key components**
- **Keep moisture, high temperature, and dirty atmosphere away from the control boards.**
- **Do not modify or weld on the pressure vessel.**
- **After maintenance, ensure no tools or rags are left inside the compressor unit.**
- **Before running the compressor, make sure the motor direction of rotation is correct.**
- **Never use combustible liquid to clean the Valve set and the Cooler.**
- **Carefully treat all the waste grease and waste water by following local Environmental Regulations.**

ROUTINE MAINTENANCE

(1) CLEAN

Always keep the unit clean.

(2) RECORD

2.1 Write down daily operating pressure and temperature shown on the indicator together with ambient air temperature on a Maintenance Record Card. The reading should be taken when conditions are stable and the unit is running on full load.

2.2 Keep a careful record of all servicing, repair and failure history. The record will become a useful reference for future maintenance.

(3) ELECTRICAL CONNECTIONS

Check electrical connections regularly. Clean and tighten all connections and repair or replace cables before starting up.

(4) LEAKAGE

Check if any leakage in the compressor system.

(5) BELT TENSION

Check the belts for tightness and adjust daily if necessary.

Configuration

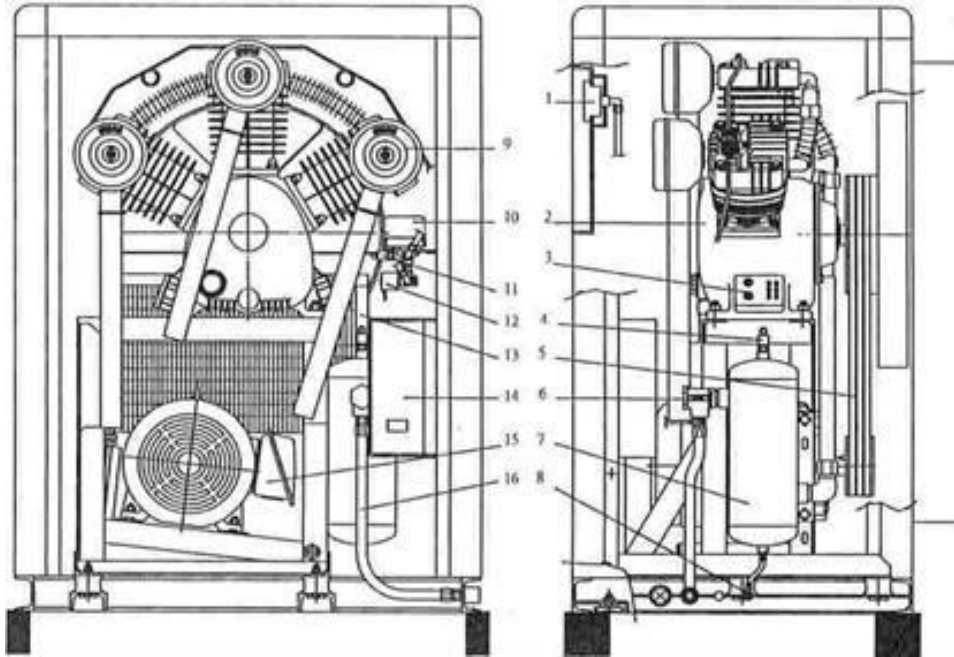

#	Description	#	Description	#	Description
1	Pressure gauge	7	Air buffer	13	After cooler
2	Bare Compressor	8	Cock	14	Control box
3	Suction Filter	9	Inlet filter	15	Motor
4	Safety valve	10	Pressure gauge	16	Rubber exhaust pipe
5	V-belt	11	Safety valve		
6	Check valve	12	Solenoid valve		

Control Panel

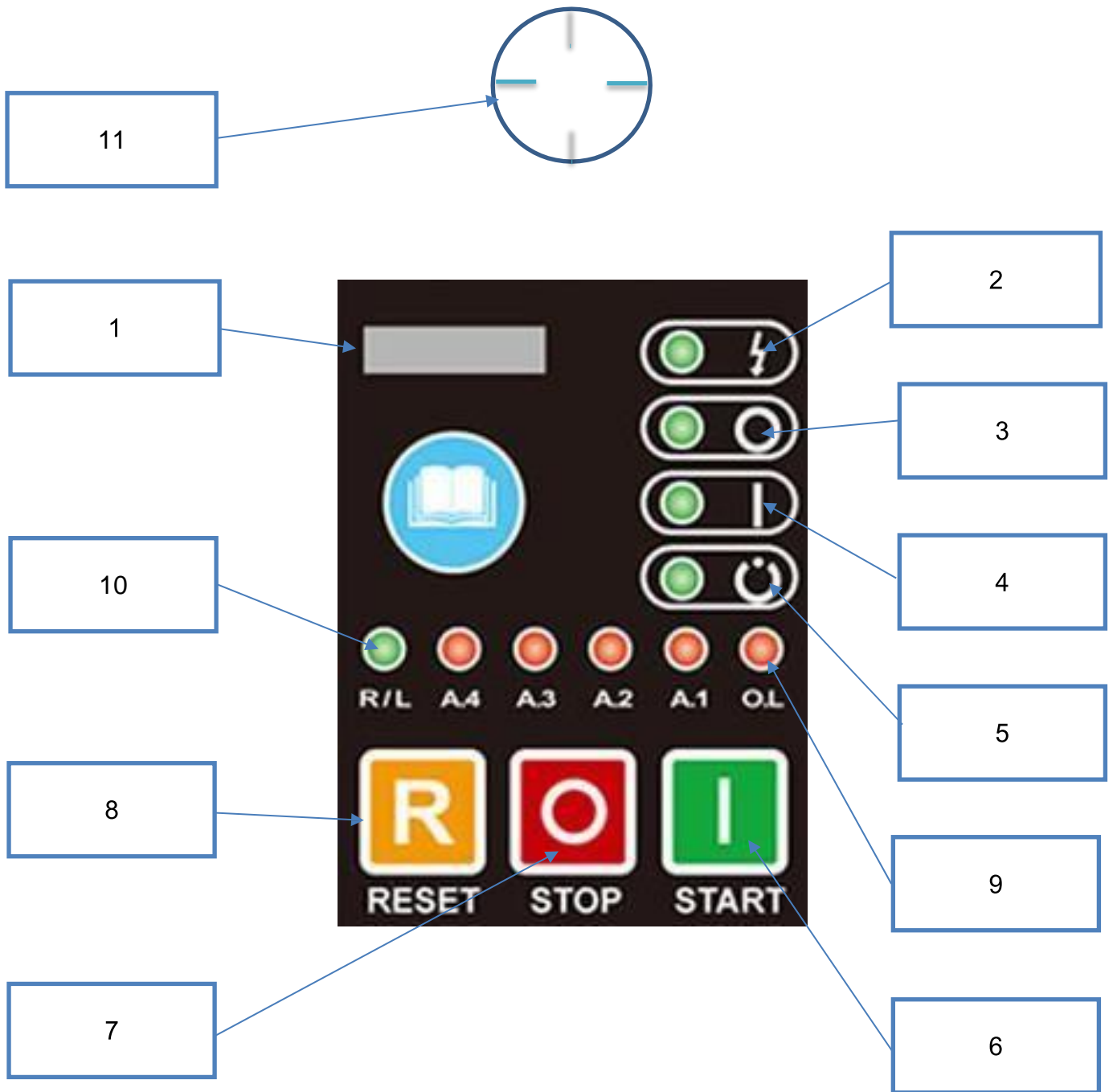

#	Description	#	Description	#	Description
1	Hour Meter	5	Stand-by Indicator	9	Overload Indicator
2	Power Indicator	6	Start	10	Remote Indicator
3	Stop Indicator	7	Stop	11	Pressure Gauge
4	Start Indicator	8	Reset		

Air compressor circuit diagram

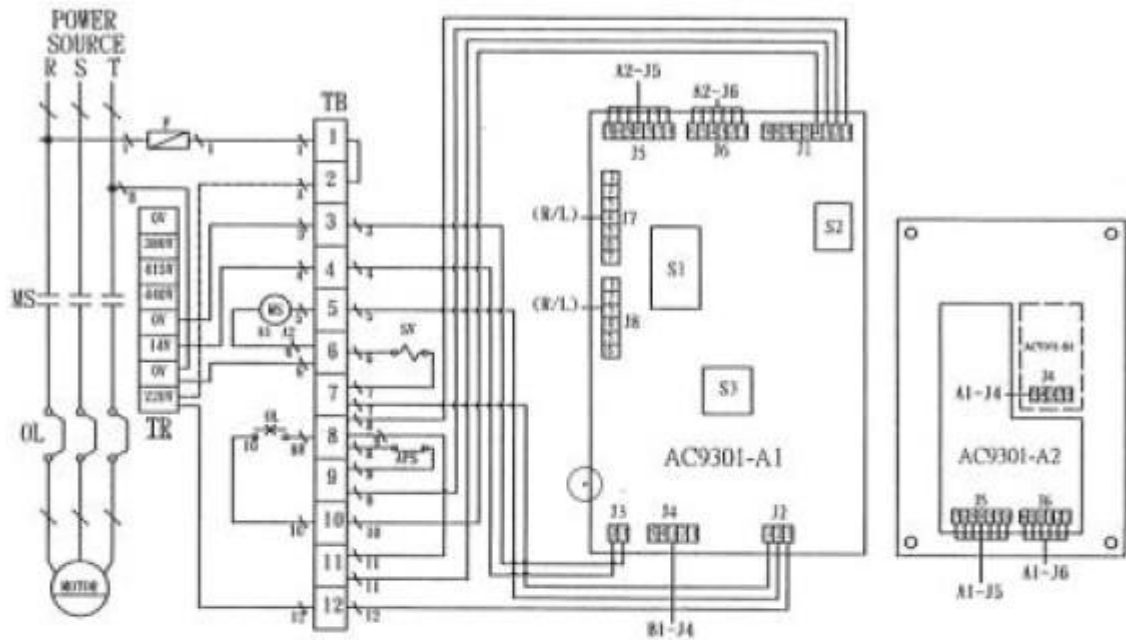

Symbol	Description	External Circuit
Power Source	Power Source	
Motor	Motor	
MS	Magnetic Contactor	
OL	Overload Relay	
F	Fuse	
TR	Transformer	
TB	Terminal Block	
SV	Solenoid Valve	6 7
APS	Air Pressure Switch	8 9
AC9301-A1	PCB Controller	
AC9301-A2	PCB Panel	
AC9301-B1	PCB Hour Meter	

TB1,2 Emergency Stop Preset Connections.

BELT MAINTENANCE

Keep the groove clean on both the Flywheel and Motor Pulley.

Align Flywheel with Pulley groove for installation of V-Belt.

Please Note Over tight belts can lead to premature wear of compressor components and reduce efficiency

Maintain the proper belt tension.

- 1) Use the belt adjuster to correct belt tightness (adjust the tightness according to belt type, center distance and belt length.
- 2) Simple testing method
Press down firmly on each individual belt and check the deflection is 15-20 mm as shown in the below image.

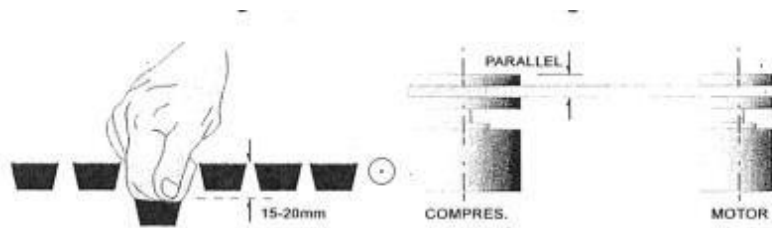

ENCLOSURE FILTER

Fitted on the cover, the pre-filter is used to screen air before intake filter. Daily check is required. If any dust accumulates, please follow the steps as below:

- (1) Remove the dust-preventive cover.**
- (2) Clean with compressed air or neutral detergent and water then dry and replace cover.**

INTAKE FILTERS

According to the Air end Maintenance Schedule, clean with compressed air or replace with a new element if necessary.

ATTENTION: Never clean filter element with solvents or water.

COOLER

After running for a period of time, cooler fins might be covered with dust so as to reduce cooling efficiency, causing higher Discharge temperature.

Clean with compressed air or neutral detergent and water if necessary.

ELECTRICAL SYSTEM

Check all the electrical connections are firmly connected ◦

TROUBLE SHOOTING

Problem		Possible Cause	Remedy
Compressor fails to start	Silent Motor	Cables loose	Check / Tighten
		Magnetic contactor fault	Check / Replace
		Panel fault	Check / Replace / Repair
		Motor failure	Check / Replace / Repair
		Phase reversal	Exchange any two cables
		Emergency switch actuated	Check / Reset
		Blown fuses	Check / Replace
	Motor buzz	Motor failure	Check / Replace / Repair
		Failure of air end	Disassemble and Repair
		Low voltage	Check / Improve power supply
Cable improper		Check / Replace	
Over-current	Low voltage	Check / Improve power supply	
	High discharge pressure	Reset pressure switch	
	Failure of air end	Disassemble and Repair	
	Motor failure	Check / Replace / Repair	
Low current	Low discharge pressure	Reset pressure switch	
	Air end rotates backward	Change phase	
	Clogged intake filter	Clean or Replace	

TROUBLE SHOOTING

Problem	Possible Cause	Remedy
High discharge temperature	High ambient temperature or bad ventilation	Improve installation environment & ventilation
	Clogging of cooler fins or enclosure filter	Clean
Safety valve activated	Failure of safety valve	Replace
	Failure of pressure switch	Check / Replace
Discharge pressure does not increase	Air leaks from pipes	Check / Replace / Repair
	Clogged intake filter	Clean / Replace
	Failure of pressure switch	Reset / Replace
	Air consumption exceeds compressor's capacity	Recalculate air consumption
	Air end rotates backward	Change phase
Abnormal sound and vibration	Failure of air end	Disassemble and Repair
	Air end rotates backward	Change phase
	Covers unlocks	Check and lock
	Loosen bolts	Check and tighten
	Motor failure	Check / Replace / Repair
	Belt slips	Check tension and readjust
	Unbalanced cooling fan	Check / Clean
Compressor stops and the air end rotates backward	Failure of Check valve	Replace / Repair
Overload relay actuated	Wrong setting	Reset
	High Discharge pressure	Check / Replace / Reset
	Failure of air end	Disassemble and Repair
	Low voltage	Check / Improve power supply
	Motor failure	Check / Replace / Repair
	Overload relay failure	Replace

WARRANTY

Pilot Air Compressors Pty Ltd manufactured goods - 1 Year Warranty and 3 Year Warranty (where applicable)

February 2012

Pilot Air Compressors Pty Ltd (Pilot Air) warrants to the first purchaser of goods (manufactured by it) (Product) from Pilot Air and the last purchaser prior to installation that, subject to compliance with the Conditions of Warranties below that:

- 1. For a period of 12 months from the date of purchase, the Product will be free from defects due to defective factory workmanship or materials; and**
- 2. For a period of 12 months from the date of purchase that Pilot Air branded accessories supplied by Pilot Air will be free from defects due to defective factory workmanship or materials.**
- 3. The compressor pump only (and excluding all other components of the unit) in the following units:**
 - TM Series Units**
 - Classic K Series Units**
 - Petrol Industrial Series Units**
 - Three Phase Industrial Series Units**

will be free from defects due to defective factory workmanship or materials for a period of 3 years from the date of purchase.
- 4. The 'SCR', 'OFP', 'DCR' and 'FP' Series of Rotary type compressors will be free from defects due to defective factory workmanship or materials for 3,000 working hours in the first 12 months from the date of purchase. This warranty is extended to a period of 2 years for the air end of the DCR and FP Series Compressors.**
- 5. Where compressors are powered with either petrol or diesel engines, the engine only is subject to the warranty provided by the manufacturer of the engine.**
- 6. Non Pilot Air accessories (meaning accessories which are not Pilot Air manufactured and branded) which are supplied by Pilot Air are not covered by this warranty. Purchasers are referred to the individual manufacturer's warranty. Purchasers can request a copy of the applicable warranties by contacting Pilot Air using the contact details below.**

PH: 1300 667 579

www.pilotair.com.au

Conditions of Warranties

- a) **The warranties specified herein are subject to the following conditions:**
- b) **Pilot Air will not be liable for a breach of any of its warranties unless the Claimant provides proof of purchase of the Product and makes a written claim to Pilot Air at the address set out below, either within 30 days after the defect would have become reasonably apparent, or if the defect was reasonably apparent prior to installation, then the claim must be made prior to installation;**
- c) **The warranties are not transferable;**
- d) **The Product must be installed, operated, maintained and serviced strictly in accordance with the relevant Pilot Air literature current at the time of installation and must be installed in conjunction with the components or products specified in the Pilot Air literature. To obtain copies of such literature go to www.pilotair.com.au or telephone Pilot Air on (02) 9648 3099;**
- e) **If the claimant chooses to rely upon any warranty specified herein the claimant's sole remedy under the warranty for breach of the warranty is (at Pilot Air's option) that Pilot Air will either supply replacement Product, rectify the affected Product or pay for the cost of the replacement or rectification of the affected product;**
- f) **In the circumstances where the guarantees under the Australian Consumer Law do not apply in respect to the purchase of its Products, Pilot Air will not be liable for any losses or damages (whether direct or indirect) including property damage or personal injury, consequential loss, economic loss or loss of profits, arising in contract or negligence or howsoever arising. Without limiting the foregoing, Pilot Air will not be liable for any claims, damages or defects arising from misuse of the Product, inadequate maintenance and storage of the Product, repairs rendered necessary or arising from the use of non-genuine Pilot Air parts in the product, normal wear and tear maintenance of the Product, deterioration of any part of the Product due to normal wear and tear, work performed on the Product other than by an authorised Pilot Air service technician or their agent, use of the Product for any purpose other than which it was intended to be used, use of the Product after essential parts and accessories have been removed, operating the Product continuously under excessive load, and if the serial/model label has been removed or obscured on the Product;**
- g) **In circumstances where the guarantees under the Australian Consumer Law do not apply in respect to the purchase of its Product/s: all warranties, conditions, liabilities and obligations other than those specified herein are excluded to the fullest extent allowed by law.**
- h) **Parts repaired or replaced under any warranty specified herein are warranted only for the remaining period of the original warranty period.**
- i) **All defective parts that are the subject of a claim under any warranty specified herein become the property of Pilot Air.**

PH: 1300 667 579

www.pilotair.com.au

- j) **The warranties specified herein do not apply to the following parts or conditions and cannot be relied upon in the situation whereby:**
- i. **any Pilot Air product or part has been subject to misuse, negligence, accidental damage, improper or inadequate use, inadequate maintenance or improper storage or been operated under unusual conditions or continuously under excessive load;**
 - ii. **the defect has been caused by the use of non genuine Pilot Air parts;**
 - iii. **the defect or deterioration was due to normal use, fair wear and tear and exposure, unless due to any defect in material or workmanship;**
 - iv. **work was undertaken on any Pilot Air product or part by an unauthorised Pilot Air agent;**
 - v. **the serial /model label has been removed from any Pilot Air product or part;**
 - vi. **normal maintenance items/parts including valves and piston rings**
- k) **Warranty repairs on all 240 Volt and portable units shall be on a back to base basis that the Claimant is required to return the Product to the nominated warranty agent as advised by Pilot Air, provided that such costs are not significant;**
- l) **The replacement or repair of any defective part or correction of operating faults under any warranty specified herein is to be made only after Pilot Air, or its authorised representative, have examined the unit to their satisfaction, with their decision being final.**
- m) **In the circumstances where Pilot Air accepts or it is determined by Pilot Air that the claimant has a valid claim under this warranty, and subject to paragraph (m) below, Pilot Air will bear all of the claimant's reasonable and proximate expenses incurred as a result of claiming under this warranty. The claimant is to inform Pilot Air in writing to the address identified below within 21 days from when the claimant first makes a claim under this warranty of all such claims and expenses and provide it with copies of all receipts and invoices where relevant before any reimbursement is made by Pilot Air to the claimant. The claimant is responsible for all other costs of claiming under this warranty.**
- n) **Pilot Air will not be responsible for any courier, transport or freight related costs whatsoever associated with the return to it of any defective Product that have not first been approved by it. Pilot Air reserves the right to first inspect any defective Product and decide how, if at all, the defective Product is to be returned to it. Any unapproved courier, transport or freight related costs will be to the claimant's account.**

PH: 1300 667 579

www.pilotair.com.au

Important Note:

If you acquire goods from Pilot Air as a consumer according to the Australian Consumer Law, our goods come with guarantees that cannot be excluded under the Australian Consumer Law. You are entitled to a replacement or refund for a major failure and for compensation for any other reasonably foreseeable loss or damage. You are also entitled to have the goods repaired or replaced if the goods fail to be of acceptable quality and the failure does not amount to a major failure.

Any rights a consumer may have under any warranty specified herein are in addition to other rights and remedies of a consumer under a law in relation to the goods to which these warranties relate. Nothing in this document shall exclude or modify any legal rights a customer may have under the Australian Consumer Law or otherwise which cannot be excluded or modified at law.

Contact details if you wish to make a claim under any warranty specified herein:

For more information or to make a claim under any warranty specified herein please telephone Pilot Air on 1300 667 579 , email Pilot Air via our website: <http://www.pilotair.com.au> or write to Pilot Air at:

**Pilot Air Compressors Pty Ltd
115 Beaconsfield St
Silverwater NSW 2128
(P O Box 277 Ermington NSW 1700)**

PH: 1300 667 579

www.pilotair.com.au