

Pilot TM420SDL+ Portable 240V Reciprocating



TM+ SERIES



Instruction and Maintenance Manual

Dear Customer,

Thank you for choosing Pilot Air.

In order to get the best performance out of this product, please read this manual carefully.

To avoid incorrect operation of the equipment and possible physical risk to the operator, please read and strictly follow the instructions contained in this manual.

Note, these instructions are in addition to the safety rules that apply in the country where the air compressor is installed.

Before packing for shipment, each machine undergoes a rigorous test to ensure the absence of any manufacturing faults and to demonstrate that the device can perform all the functions for which it has been designed.

This manual must be maintained available in any moment for future references and it has to be intended as inherent part of the relevant dryer.

Due to the continuous technical evolution, we reserve the right to introduce any necessary change without giving previous notice.

Should you experience any trouble, or for further information, please do not hesitate to contact us.

Best Regards,



PILOT AIR COMPRESSORS

<http://www.pilotair.com>

Phone: 1300 667 579

Email: service@pilotair.com.au / spares@pilotair.com.au

SYMBOLS



Read the operator's instruction



Warning: Hazard



Shock hazard



Unit is remotely controlled and may start without warning



To stop the compressor, use the switch located on the pressure switch body. Never use the main switch or unplug the compressor.



INDEX

GB

1	General Information	5
2	Safety	7
3	Operating the Compressor	8
4	Maintenance	9
5	Fault Finding	11
6	Warrant Terms and Conditions	13

1. General Information

IDENTIFYING THE PRODUCT

The product is identified by an EC label (see fig.1)

- 1 Manufacturer's Data
- 2 CE mark – year of manufacture
- 3 TYPE / CODE / SERIAL N
- 4 Air delivered by the compressor expressed in (l/min) And (cfm)
- 5 Max. operating pressure (bar and PSI) – compressor
- 6 Noise level in dB(A)
- 7 Electric data: voltage (V/ph), frequency (Hz), absorption (A) power (HP and kW), rotations per minute (Rpm).
Other approvals

Fig 1

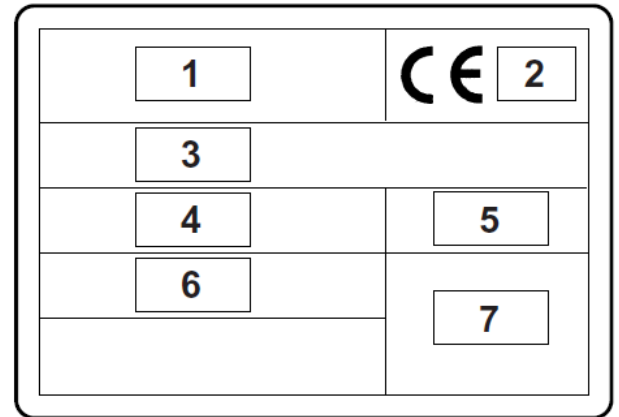

IMPORTANT! READ ME.

Compressors fitted with: FD2000, FD2500, OL185, OL195, OL230, MK6, FD9200, FD9300 and SF2500 pump units are designed for intermittent use, the duty cycle should not exceed 50% and they should not be operated continuously for more than 15 minutes.

***Compressors rated at more than 5.5 hp must only be used in closed environments.**

UNPACKING

- **The packaging may include metal staples, always wear safety gloves and use pliers when removing them.**
- Ensure the lifting device is capable of supporting the weight. In the case of compressors with a capacity of greater than 50 litres, take special care not to overbalance the machine, ensure that transportation is carried out by personnel who have been trained in the use of the lifting equipment and that there are no persons or obstacles of any kind present in the area where it is to be moved.
- Ensure that the compressor is in perfect condition and that the following items are present: User and Maintenance manual, oil level dipstick, wheels and/or vibration dampers, air intake filter (if necessary, fit the wheels and/or vibration dampers, see fig.2).

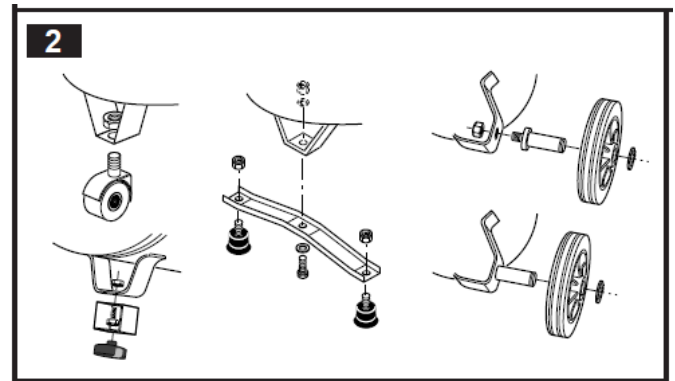

POSITIONING

- DO NOT USE the compressor if it is installed on floors with a slope of more than 15° (fig.3).
- Always position the compressor **at least 50 cm** from any obstacles that could obstruct the passage of air and hence affect the cooling system.

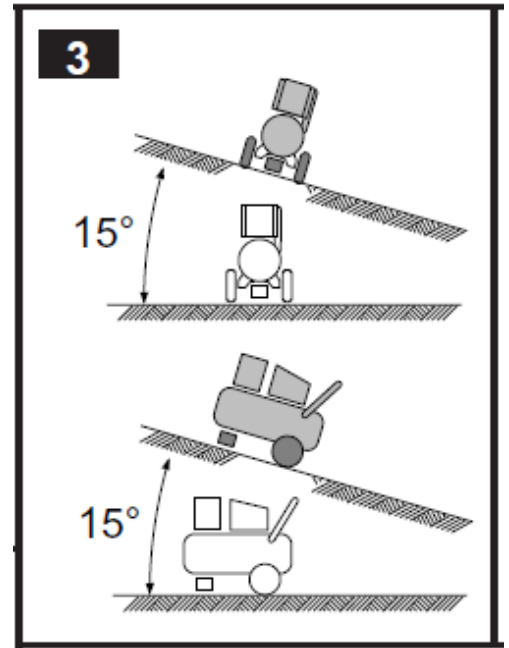

DISPOSAL

- Keep the packaging in case it is necessary to move to another location, or at least until the guarantee expires.
- The packaging material, the compressor and its components must be disposed of by authorised recycling centres.

INFORMATION ABOUT TECHNICAL ASSISTANCE

Repairs under guarantee may only be carried out by our authorised technicians. Use original spare parts only. Whatever your request, always indicate the **TYPE, CODE and SERIAL NO** of your compressor.

2. Safety

The compressor must be used **exclusively** as a **compressed air** generator, all other uses are excluded. The manufacturer declines all responsibility for damages in cases where the machine is misused, or used in a way that does not conform to the operating instructions.

DO

- **M**ake sure you understand how to switch off the compressor, and how to use all the controls.
- **E**mpy the air tank and disconnect the electrical supply before carrying out any operations, in order to avoid starting up the machine by accident.
- **E**nsure that you have replaced all parts correctly after carrying out any maintenance operations.
- **K**eeP children and animals away from the area where the compressor is operating.
- **C**arefully read the instructions provided with any accessories that may be fitted; in particular, when using the paint spray gun ensure that the area is properly ventilated.
- **U**se acoustic protection devices if you are present in the area where the compressor is running for prolonged periods.

DO NOT

- **U**se the machine for spray painting in closed environments or near to naked flames.
- **T**ouch the head, the cylinders, the cooling fins or feeder tube as these can reach high temperatures during operation, and may take some time to cool down again after the compressor has been switched off.
- **P**lace inflammable materials on and/or near the compressor.
- **M**ove the compressor when the air tank is pressurised.
- **U**se the machine if the power cable is damaged, or the electrical connection is unsafe.
- **P**oint the air jet at people or animals.
- **A**llow anyone to use the compressor unless they have been properly trained.
- **S**trike the flywheel or the fans with blunt or metallic objects. This could cause them to break while the compressor is running.
- **O**perate the compressor without the air filter.
- **T**amper with the safety valve and/or the air tank.
- **O**perate the compressor in a potentially explosive atmosphere.
- **C**onnect tubes that are rated at less than the maximum capacity of the compressor to the outlet valve.
- **U**se the compressor at temperatures below 0°C (range temp. +5° C to + 45° C).

PROTECTING THE MOTOR

- **SINGLE PHASE** compressors are fitted with a motor-protector, which automatically interrupts the electrical power supply if an overload occurs. In this case, disconnect the power supply and wait a few minutes before resetting the motor-protector manually (fig.4), then restart the compressor. If the motor-protector trips again, disconnect the power supply and contact an authorised service centre.
- **THREE PHASE** compressors are fitted with an internal motor protection device, which stops the compressor if an overload occurs. **In this case, call a specialised technician** in order to recalibrate or adjust the thermal relay, as required.

N.B – In the case of models equipped with “OIL CONTROL” the protection device may stop the compressor if the oil is low, check the level, and top-up if necessary.

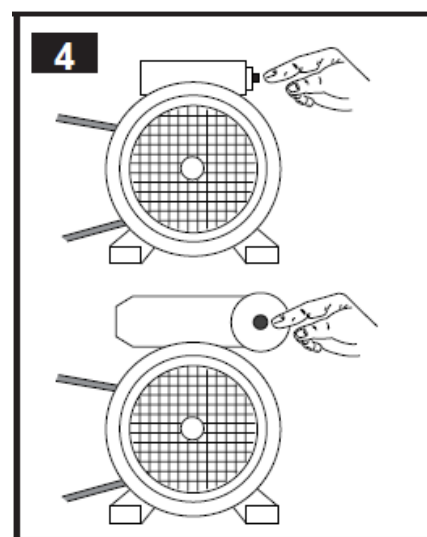

3. Operating the Compressor

INSTALLATION (FIG.5)

- 1) Remove the guard cover cap and insert the oil level dipstick.
- 2) Check that the oil level is between the minimum and maximum markers indicated in the window or on the dipstick.
- 3) Check that the mains voltage corresponds to the value indicated on the EC label.

Single phase Compressors: are fitted with an EEC type 7 plug. If necessary this may be substituted by specialised personnel only.

Three phase compressors: are supplied without a plug. They must be connected to the mains supply via a correctly rated thermo-magnetic breaker switch. This operation must be carried out by a qualified electrician in accordance with the procedure described in table 1 (page 12).

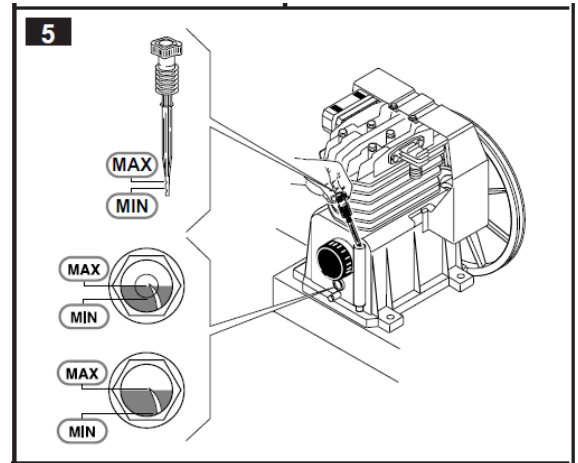

SWITCHING THE COMPRESSOR ON (FIG.6)

- Insert the mains plug, or apply the mains supply to the breaker switch, and start the machine by switching the ON/OFF switch to ON.
- The first time the compressor is switched on, leave it to run for about ten minutes with the air output valves (A) open. Close the valves and check that the compressor pressurises the air tank, stopping when it reaches the Pmax (as indicated by the manometer B).
- The compressor operates in automatic mode, stopping when the pressure reaches Pmax and restarting when the pressure falls to the calibrated minimum value (P max - 2 bar).
- Some models are equipped with an idle operation feature; in such cases the compressor does not switch off immediately, but “idles” for a few minutes until the “excess” air has been expelled via a valve/solenoid valve. You can adjust this function so that switch off can be delayed by between 1 to 6 minutes when it is in continuous use. Once six minutes have elapsed, the compressor will switch off automatically.
- The only correct way to switch off the compressor is by switching the ON/OFF switch to OFF.

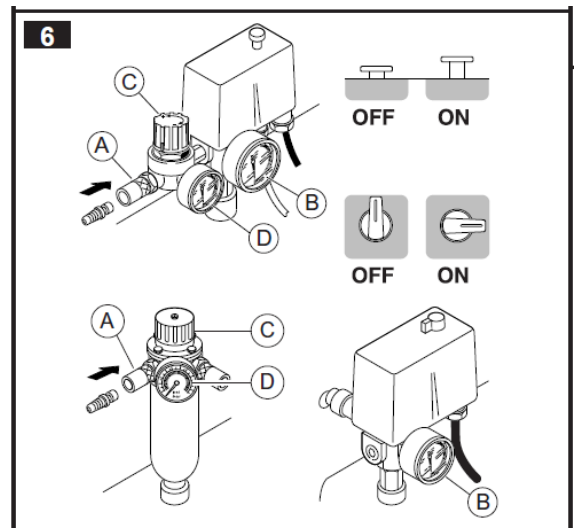

When the compressor is operating correctly it releases: a puff of compressed air each time it is switched off; a prolonged puff of air each time it is switched on.

SETTING UP THE WORKING PRESSURE (FIG.6)

- You can regulate the output pressure, which is indicated by the manometer D, by adjusting the reducer C. After use, the pressure should be allowed to fall to zero. When using pneumatic tools, always check the optimum working pressure of the accessory.
- In the case of machines that are not equipped with a reducer, the user must install an appropriate safety device in the line.

4. Maintenance

MAINTENANCE

Turn the compressor off and let all the air out of the tank before carrying out any maintenance.

After operating for 50 hours

- Check that all the screws are tight, particularly those securing the head and the base
- Change the oil (see paragraph "Once every 6 months")

Once a week

- Check the **oil level** and top it up if necessary using ONLY the same type of oil (do not exceed the max. level - see fig.5).
- **Discharge the condensation** by opening the valve located under the tank; close the valve as soon as it begins to vent air only (fig.7).

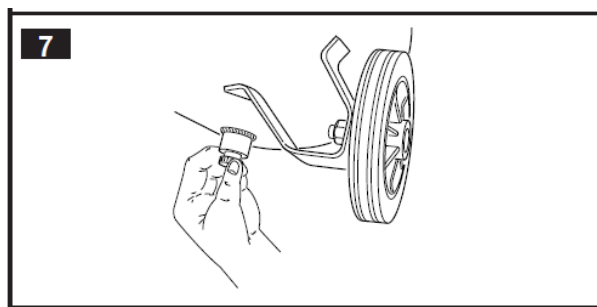

Once a month (or more frequently if used in a dusty environment)

- Remove the **intake filter** and clean the filter element (fig. 8) or replace it if it is damaged.
- PAPER element: clean by directing a jet of compressed air through it from the inside towards the outside – SPONGE element: wash using a detergent, rinse and dry thoroughly - METAL element: wash using an oil-free diluting agent and blow dry using compressed air.
- Do not operate the compressor without the intake filter.

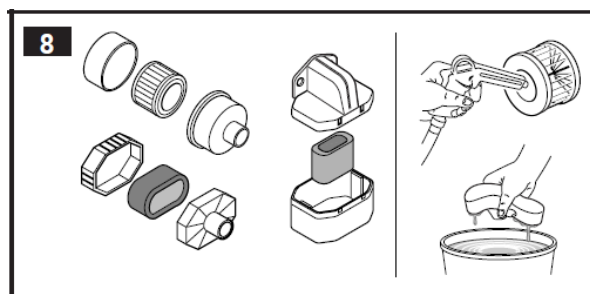

Once every 6 months:

- **Change the oil** (while the compressor is warm): extract the level dipstick, undo screw **A** (fig.9) and collect the waste oil in a recipient. Replace the screw **A** and replenish with new oil up to the maximum level.

Original oil: mineral oil15W-50. **Never mix different oils.**

N.B. The **BKV40** unit is equipped with the "Oil Control" system (optional on other models) that interrupts the power supply and prevents the compressor from restarting when the level drops below the minimum value.

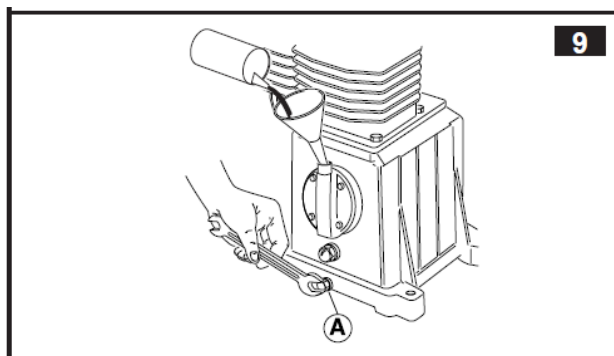

4. Maintenance

- **Clean** all the finned parts thoroughly.
- **Check the belt tension.** The belt must flex by approximately 10 mm when a 3 Kg load is applied (fig.10). Reset the tension if necessary, ensuring that the pulley and flywheel remain correctly aligned. Some models are not equipped with a regulator for performing this adjustment, in this case you are advised to call a specialised technician.

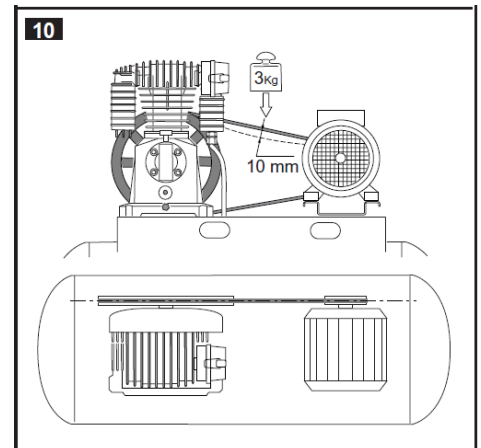

Once every 2 years

- Check the valve seal and substitute the sealing element **D** if necessary (fig.11).
- Check the intake and discharge valves.

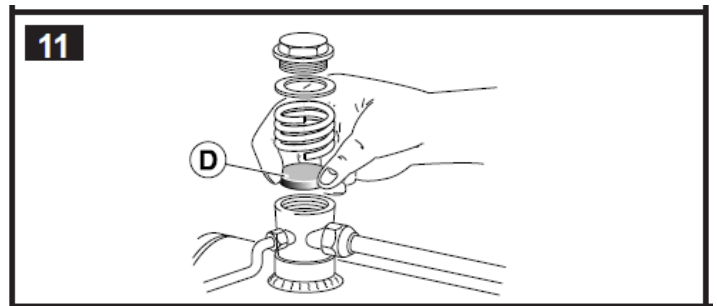

5. Fault Finding

FAULT	SOLUTION
1. The tank pressure decreases.	1. Check that all the connectors are closed correctly. If the problem persists call technical assistance
2. Air leaks from the pressurestat valve when the compressor is not running.	2. Clean the valve seal seat thoroughly. Substitute the sealing element if necessary.
3. Air leaks from the pressurestat valve when the compressor has been running for more than 1 minute.	3. Idle start valve faulty. Stop the compressor and call technical assistance.
4. The compressor stops and will not restart.	4.1 Disconnect the power supply, wait a few minutes, then press the motor-protector button. If the motor-protector trips again when the compressor is restarted, call technical assistance 4.2 The motor winding is burnt out, contact an service centre.
5. The compressor does not stop when it reaches P_{max} , causing the safety valve to open	5. The pressurestat may be faulty. Stop the compressor and call technical assistance
6. The compressor fails to pressurise the tank, and overheats.	6. Blown head gasket or faulty valve. Stop the compressor immediately and call technical assistance.
7. The compressor is very noisy; rhythmic and metallic knocking sounds can be heard.	7. The bushing or ferrule may have become seized. Stop the compressor immediately and call technical assistance
8. The compressor runs slowly.	8. Reset the belt tension

Table 1

	GB	Absorption	Direct start relay setting	Start/delta relay setting	Cable cross section	Switch
HP	V/Hz/ph	A	A	A	mm ²	A
2	230/50/3	6	6,5	-	1	10
	400/50/3	3,5	3,9	-	1	6
3	230/50/3	8,7	9,2	-	1,5	16
	400/50/3	5	5,4	-	1	10
4	230/50/3	12	12,6	7	1.05	30
	400/50/3	7	7,4	4	1	20
5,5	230/50/3	15,7	16,5	9,5	2,5	36
	400/50/3	9	9,5	5,5	1,5	25
7,5	230/50/3	21,7	22,5	13,1	4	50
	400/50/3	12,5	13,1	7,6	2,5	30
10	230/50/3	27,7	28,8	16,5	4	50
	400/50/3	16	16,5	10	2,5	36
15	230/50/3	39	-	23	6	80
	400/50/3	22,5	-	13,4	4	40
20	230/50/3	54	-	32	10	80
	400/50/3	31,2	-	18,5	6	50

Warranty

Pilot Air Compressors Pty Ltd **manufactured goods - 1 Year Warranty and 3 Year Warranty (where applicable)**

(DATE)

Pilot Air Compressors Pty Ltd (**Pilot Air**) warrants to the first purchaser of goods (manufactured by it) (Product) from Pilot Air and the last purchaser prior to installation that, subject to compliance with the Conditions of Warranties below that:

1. For a period of 12 months from the date of purchase, the Product will be free from defects due to defective factory workmanship or materials; and
2. For a period of 12 months from the date of purchase that Pilot Air branded accessories supplied by Pilot Air will be free from defects due to defective factory workmanship or materials.
3. The compressor pump only (and excluding all other components of the unit) in the following units:
 - a. TM Series Units
 - b. Classic K Series Units
 - c. Petrol Industrial Series Units
 - d. Three Phase Industrial Series Units

will be free from defects due to defective factory workmanship or materials for a period of 3 years from the date of purchase.

4. The 'ALTA TEC', 'DCR', 'PAC' and 'FP' Series of Rotary Screw type compressors will be free from defects due to defective factory workmanship or materials for 3,000 working hours in the first 12 months from the date of purchase. This warranty is extended to a period of 2 years for the air end of the DCR PAC and FP Series Compressors.
5. Where compressors are powered with either petrol or diesel engines, the engine only is subject to the warranty provided by the manufacturer of the engine.
6. Non-Pilot Air accessories (meaning accessories which are not Pilot Air manufactured and branded) which are supplied by Pilot Air are not covered by this warranty. Purchasers are referred to the individual manufacturer's warranty. Purchasers can request a copy of the applicable warranties by contacting Pilot Air using the contact details below.

Warranty

Conditions of Warranties

The warranties specified herein are subject to the following conditions:

- (a) Pilot Air will not be liable for a breach of any of its warranties unless the Claimant provides proof of purchase of the Product and makes a written claim to Pilot Air at the address set out below, either within 30 days after the defect would have become reasonably apparent, or if the defect was reasonably apparent prior to installation, then the claim must be made prior to installation;
- (b) The warranties are not transferable;
- (c) The Product must be installed, operated, maintained and serviced strictly in accordance with the relevant Pilot Air literature current at the time of installation and must be installed in conjunction with the components or products specified in the Pilot Air literature. To obtain copies of such literature go to www.pilotair.com.au or telephone Pilot Air on (02) 9648 3099;
- (d) If the claimant chooses to rely upon any warranty specified herein the claimant's sole remedy under the warranty for breach of the warranty is (at Pilot Air's option) that Pilot Air will either supply replacement Product, rectify the affected Product or pay for the cost of the replacement or rectification of the affected product;
- (e) In the circumstances where the guarantees under the Australian Consumer Law do not apply in respect to the purchase of its Products, Pilot Air will not be liable for any losses or damages (whether direct or indirect) including property damage or personal injury, consequential loss, economic loss or loss of profits, arising in contract or negligence or howsoever arising. Without limiting the foregoing, Pilot Air will not be liable for any claims, damages or defects arising from misuse of the Product, inadequate maintenance and storage of the Product, repairs rendered necessary or arising from the use of non- genuine Pilot Air parts in the product, normal wear and tear maintenance of the Product, deterioration of any part of the Product due to normal wear and tear, work performed on the Product other than by an authorised Pilot Air service technician or their agent, use of the Product for any purpose other than which it was intended to be used, use of the Product after essential parts and accessories have been removed, operating the Product continuously under excessive load, and if the serial/model label has been removed or obscured on the Product;
- (f) In circumstances where the guarantees under the Australian Consumer Law do not apply in respect to the purchase of its Product/s: all warranties, conditions, liabilities and obligations other than those specified herein are excluded to the fullest extent allowed by law.

Warranty

- (g) Parts repaired or replaced under any warranty specified herein are warranted only for the remaining period of the original warranty period.
- (h) All defective parts that are the subject of a claim under any warranty specified herein become the property of Pilot Air.
- (i) The warranties specified herein do not apply to the following parts or conditions and cannot be relied upon in the situation whereby:
 - i) any Pilot Air product or part has been subject to misuse, negligence, accidental damage, improper or inadequate use, inadequate maintenance or improper storage or been operated under unusual conditions or continuously under excessive load;
 - ii) the defect has been caused by the use of non-genuine Pilot Air parts;
 - ii) the defect or deterioration was due to normal use, fair wear and tear and exposure, unless due to any defect in material or workmanship;
 - iv) work was undertaken on any Pilot Air product or part by an unauthorised Pilot Air agent;
 - v) the serial /model label has been removed from any Pilot Air product or part;
 - vi) normal maintenance items/parts including valves and piston rings
- (j) Warranty repairs on all 240 Volt and portable units shall be on a back to base basis that the Claimant is required to return the Product to the nominated warranty agent as advised by Pilot Air, provided that such costs are not significant;
- (k) The replacement or repair of any defective part or correction of operating faults under any warranty specified herein is to be made only after Pilot Air, or its authorised representative, have examined the unit to their satisfaction, with their decision being final.
- (l) In the circumstances where Pilot Air accepts or it is determined by Pilot Air that the claimant has a valid claim under this warranty, and subject to paragraph (m) below, Pilot Air will bear all of the claimant's reasonable and proximate expenses incurred as a result of claiming under this warranty. The claimant is to inform Pilot Air in writing to the address identified below within 21 days from when the claimant first makes a claim under this warranty of all such claims and expenses and provide it with copies of all receipts and invoices where relevant before any reimbursement is made by Pilot Air to the claimant. The claimant is responsible for all other costs of claiming under this warranty.

Warranty

- (m) Pilot Air will not be responsible for any courier, transport or freight related costs whatsoever associated with the return to it of any defective Product that have not first been approved by it. Pilot Air reserves the right to first inspect any defective Product and decide how, if at all, the defective Product is to be returned to it. Any unapproved courier, transport or freight related costs will be to the claimant's account.

Important Note:

If you acquire goods from Pilot Air as a consumer according to the Australian Consumer Law, our goods come with guarantees that cannot be excluded under the Australian Consumer Law. You are entitled to a replacement or refund for a major failure and for compensation for any other reasonably foreseeable loss or damage. You are also entitled to have the goods repaired or replaced if the goods fail to be of acceptable quality and the failure does not amount to a major failure.

Any rights a consumer may have under any warranty specified herein are in addition to other rights and remedies of a consumer under a law in relation to the goods to which these warranties relate. Nothing in this document shall exclude or modify any legal rights a customer may have under the Australian Consumer Law or otherwise which cannot be excluded or modified at law.

Contact details if you wish to make a claim under any warranty specified herein:

For more information or to make a claim under any warranty specified herein please telephone Pilot Air on (02) 9648 3099, email Pilot Air via our website: <http://www.pilotair.com.au> or write to Pilot Air at:

Pilot Air Compressors Pty Ltd 115 Beaconsfield Road
Silverwater NSW 2128