



User & Maintenance Manual

**Pilot Air FP Rotary Screw
Compressors**

FP10002/240V-RM

2.2 kW

PILOT AIR COMPRESSORS

115 Beaconsfield Street, Silverwater. NSW 2128.

PH 02 9648 3099

SALES@PILOTAIR.COM.AU

SERVICE@PILOTAIR.COM.AU

PILOT AIR COMPRESSORS

2/339 Archerfield Rd, Richlands. QLD 4077

PH 07 3279 1213

SALES@PILOTAIR.COM.AU

SERVICE@PILOTAIR.COM.AU

USE AND MAINTENANCE MANUAL

SILENT ELECTRIC ROTARY SCREW COMPRESSORS

**WARNING:**

Read this manual carefully and in full before using the compressor.



IMPORTANT INFORMATION

Read all the operational instructions, safety recommendations and all warnings provided in the instruction manual. Most accidents encountered when using the compressor are merely due to the failed observance of basic safety standards. Accidents are prevented by foreseeing potentially hazardous situations and observing the appropriate safety standards. The fundamental safety standards are listed in the "SAFETY" section of this manual and also in the section involving the use and maintenance of the compressor. Hazardous situations to be avoided in order to prevent serious personal injuries and machine damages are listed in the "WARNINGS" section of the instruction manual or are actually printed on the machine. Never use the compressor improperly but only as recommended by the Manufacturer. The Manufacturer reserves the right to up-date the technical information given in this manual without notice.

0	Foreword	4
0.1	How to read and use the instruction manual	4
0.1a	Importance of the manual	4
0.1b	Conserving the manual	4
0.1c	Consulting the manual	4
0.1d	Symbols used	4
1	General information	5
1.1	Identification data of the manufacturer and the compressor	5
1.2	Information on machine technical/maintenance service	5
1.3	General safety warnings	6
2	Preliminary machine information	8
2.1	General description	8
2.2	Intended use	8
2.3	Technical data	9
3	Transport, Handling, Storage	10
3.1	Transporting and handling the packed machine	10
3.2	Packing, unpacking and prepare to use	10
3.3	Storing the packed and unpacked compressor	11
4	Installation	12
4.1	Admitted surrounding conditions	12
4.2	Space required for maintenance	12
4.3	Positioning the compressor	12
4.4	Connecting the compressor to the sources of energy and relative inspections	13
4.4.1	Connecting to the electric mains	13
4.4.2	Connecting to the pneumatic mains	14
5	Using the compressor	15
5.1	Preparing to use the compressor	15
5.1.1	Operational principle	15
5.2	Control panel	16
5.3	Check the efficiency of the safety devices before starting	16
5.4	Starting the compressor	16
5.5	Stopping the compressor	17
6	Compressor maintenance	18
6.1	Instructions relative to inspections and maintenance jobs	18
6.1.1	Oil change	19
6.1.2	Replacing the oil filter cartridge	20
6.1.3	Replacing the filter cartridge oil separator	20
6.1.4	Replacing the air filter cartridge	21
6.1.5	Draining the condensate	21
6.1.6	Cleaning the air/oil radiator	22
6.1.7	Lubricating the electric motor	22
6.2	Diagnosing the alarm status/inconveniences-faults	23
7	Drawings and diagrams	25
7.1	Wiring diagrams	25
7.2	Pneumatic diagrams	28

0.1 How to read and use the instruction manual

0.1.a Importance of the manual

This INSTRUCTION MANUAL has been written to guide you through the INSTALLATION, USE and MAINTENANCE of the compressor purchased.

We recommend that you strictly observe all the indications given within as the ideal operational efficiency and lasting wear of the compressor depend on the correct use and methodical application of the maintenance instructions given hereafter.

Remember that when any doubts or inconveniences arise it is a good rule to always contact the AUTHORISED SERVICE CENTRES. They are at your complete disposal for any explanations or jobs required.

The Manufacturer therefore declines all liabilities regarding the incorrect use and poor maintenance of the compressor. The INSTRUCTION MANUAL is integral part of the compressor.

Ensure that any up-dates forwarded by the Manufacturer are actually added to the manual.

If the compressor is sold on at a later date the manual must be given to the new owner.

0.1.b Conserving the manual

Use and read the manual with care being careful not to damage any part of it.

Do not remove, tear or re-write any parts of the manual for any reason whatsoever.

Keep the manual in a dry and sheltered place.

0.1.c Consulting the manual

This instruction manual is made up of the following:

- FRONT COVER WITH MACHINE IDENTIFICATION
- DETAILED INDEX
- INSTRUCTIONS AND/OR NOTES ON THE COMPRESSOR





The model and serial number of the compressor to which the manual refers and that you have purchased is found on the FRONT COVER.

The various SECTIONS in which all the notes relative to a certain subject are found in the INDEX.

All the INSTRUCTIONS AND/OR NOTES ON THE COMPRESSOR aim at pointing out safety warnings and procedures required to use the compressor correctly.

0.1.d Symbols used

The SYMBOLS pointed out below are used throughout this manual and their purpose is that of drawing the operator's attention, informing the latter how to behave and how to proceed in each operational situation.

	<p>READ THE INSTRUCTION MANUAL Read the use and maintenance manual carefully before installing and starting the compressor.</p>
	<p>GENERAL HAZARDOUS SITUATION An additional note will point out the type of hazard involved. Meaning of the indications:</p>
Warning!	<p>This points out a potentially hazardous situation, which if ignored, could cause personal injury and machine damage.</p>
Note!	<p>This enhances crucial information.</p>
	<p>RISK OF ELECTRIC SHOCK Warning: the electrical power supply of the compressor must be disconnected before doing any jobs on the compressor.</p>
	<p>RISK OF SCOLDING Warning: be careful when touching the compressor as some parts of it could be very hot.</p>

1.1 Identification data of the manufacturer and the compressor

COMPRESSOR IDENTIFICATION NAME PLATE.
(Silent electric rotary screw compressor on tank)



		CE	
TIPO	<input type="text"/>	N.SERIE	<input type="text"/>
TYPE	<input type="text"/>	SERIAL N.	<input type="text"/>
ANNO DI PRODUZIONE	<input type="text"/>	PRESSIONE MAX.	<input type="text"/>
YEAR OF PRODUCTION	<input type="text"/>	MAX. PRESSURE	bar <input type="text"/>
ARIA RESA	<input type="text"/>	POTENZA ASSORBITA	<input type="text"/>
F.A.D.	l/min <input type="text"/>	INPUT POWER	kw <input type="text"/>
VOLT/Hz/PH	<input type="text"/>	LIVELLO SONORO	<input type="text"/>
		NOISE LEVEL	dB(A) <input type="text"/>
COD.	<input type="text"/>	PESO	Kg/lbs <input type="text"/>
CODE	<input type="text"/>	RPM	min-1 <input type="text"/>

1.2 Information on machine technical/maintenance service

We remind you that our technical service department is at your complete disposal to help you resolve any problems that may possibly be encountered, or to provide you with any other information necessary.

In the case of need contact:

Our **CUSTOMER TECHNICAL SERVICE** department or your local dealer.

The constant and efficient performance of the compressor is ensured only if original spare parts are used.

It's recommended to visit the web site <http://www.fiac-assistance.com>

We recommend therefore that you strictly observe the indications provided in the MAINTENANCE section and to use **EXCLUSIVELY** original spare parts.

The use of NON ORIGINAL spare parts automatically annuls the guarantee.

1.3 General safety warnings

Nota! Le operazioni che troverete dentro questo manuale sono state scritte per assistere l'operatore durante l'utilizzo e le operazioni di mantenimento del compressore.



IMPORTANT INSTRUCTIONS FOR THE SAFE USE OF THE COMPRESSOR

WARNING: THE INAPPROPRIATE USE AND POOR MAINTENANCE OF THIS COMPRESSOR MAY CAUSE PHYSICAL INJURY TO THE USER. YOU ARE RECOMMENDED TO CAREFULLY FOLLOW THE INSTRUCTIONS PROVIDED HEREFTER TO AVOID SUCH RISKS.

1. **DO NOT TOUCH MOVING PARTS**
Never put your hands, fingers or other parts of the body near moving parts of the compressor.
2. **NEVER USE THE COMPRESSOR WITHOUT THE SAFETY GUARDS FITTED**
Never use the compressor without all the safety guards fitted perfectly in their correct place (i.e. panelling, belt guard, safety valve). If these parts are to be removed for maintenance or servicing purposes, ensure that they are put back in their original place perfectly before using the compressor again.
3. **ALWAYS WEAR SAFETY GOGGLES**
Always wear goggles or equivalent eye protection means. Never direct compressed air towards any part of your body or that of others.
4. **PROTECT YOURSELF AGAINST ELECTRIC SHOCKS**
Avoid accidentally touching the metal parts of the compressor with your body, such as pipes, the tank or metal parts connected to earth. Never use the compressor where there is water or in damp rooms.
5. **DISCONNECT THE COMPRESSOR**
Disconnect the compressor from the electric power supply and completely discharge the pressure from the tank before carrying out any service, inspection, maintenance, cleaning, replacing or inspection jobs of each part.
6. **ACCIDENTAL START-UP**
Never move the compressor while it is connected to the electrical power supply or when the tank is pressurised. Ensure that the main switch is turned OFF before connecting the compressor to the electrical power supply.
7. **STORE THE COMPRESSOR APPROPRIATELY**
When the compressor is not in use, it must be stored in a dry room away from atmospheric agents. Keep it out of children's reach.
8. **OPERATIONAL AREA**
Keep the work area clean and remove any tools that are not required. Keep the work area sufficiently ventilated. Never use the compressor in the presence of flammable liquids or gas. The compressor may produce sparks while running. Do not use the compressor where there may be paints, gasoline, chemical compounds, glues and any other flammable or explosive material.
9. **KEEP THE COMPRESSOR OUT OF CHILDREN'S REACH**
Prevent children or anyone else from touching the power supply cable of the compressor. All outsiders must be kept at a safe distance from the operational area.
10. **WORK CLOTHES**
Do not wear unsuitable clothing, ties or jewellery as these may get caught up in moving parts. Wear caps to cover your hair if necessary.
11. **PRECAUTIONS FOR THE POWER SUPPLY CABLE**
Do not disconnect the power supply plug by pulling on the cable. Keep the cable away from heat, oil and sharp edges. Do not stand on the electrical cable or squash it under heavy weights.
12. **LOOK AFTER THE COMPRESSOR WITH CARE**
Follow the maintenance instructions. Inspect the power supply cable on a periodic basis and if damaged it must be repaired or replaced by an authorised service centre. Visually check the outside appearance of the compressor, ensuring that there are no visual anomalies. Contact your nearest service centre if necessary.
13. **ELECTRICAL EXTENSIONS FOR OUTDOOR USE**
When the compressor is used outdoors, use only electrical extensions manufactured for outdoor use and marked as such.
14. **WARNING**
Pay attention to everything you do. Use your common sense.
Do not use the compressor if you are tired. The compressor must never be used if you are under the effect of alcohol, drugs or medicines, which could make you tired.
15. **CHECK FAULTY PARTS OR AIR LEAKS**
Before using the compressor again, if a safety guard or other parts are damaged, they must be checked carefully to evaluate whether they may operate as established in complete safety.
Check the alignment of moving parts, hoses, gauges, pressure reducers, pneumatic connections and every other part that may be crucial for the normal operational efficiency of the compressor. All damaged parts must be properly repaired or replaced by an authorised service centre or replaced following the instructions provided in instruction manual.

16. **USE THE COMPRESSOR EXCLUSIVELY FOR THE APPLICATIONS SPECIFIED IN THIS INSTRUCTION MANUAL.**
The compressor is a machine that produces compressed air.
Never use the compressor for purposes other than those specified in the instruction manual.
17. **USE THE COMPRESSOR CORRECTLY**
Operate the compressor in compliance with the instructions provided in this manual. Do not allow children to use the compressor or those who are not familiar with it.
18. **ENSURE THAT EACH SCREW, BOLT AND GUARD IS FIRMLY SECURED IN PLACE.**
19. **KEEP THE IN-TAKE GRIDS CLEAN**
Keep the motor ventilation grids clean. Regularly clean these grids if the work area is particularly dirty.
20. **OPERATE THE COMPRESSOR AT THE RATED VOLTAGE**
Operate the compressor at the voltage specified on the electric data plate. You could damage or burn-out the motor and other electric components if the compressor is operated at a higher or lower voltage than its rated voltage.
21. **NEVER USE THE COMPRESSOR IF IT IS FAULTY**
If the compressor is noisy or vibrates excessively when running or it seems to be faulty, stop it immediately and check its efficiency or contact your nearest authorised service centre.
22. **DO NOT CLEAN PLASTIC PARTS USING SOLVENTS**
Solvents such as gasoline, thinners, gas oil or other compounds that contain hydrocarbons may damage the plastic parts. Clean them with a soft cloth and soapy water or other suitable liquids.
23. **USE ORIGINAL SPARE PARTS ONLY**
The use of non-original spare parts involves the annulment of the guarantee and the abnormal running conditions of the compressor. Original spare parts are available c/o the authorised dealers.
24. **DO NOT MODIFY THE COMPRESSOR**
Do not modify the compressor. Contact an authorised service centre for all repairs required. An unauthorised modification may impair the efficiency of the compressor and may also cause serious accidents for those who do not have the technical skill required to make such modifications.
25. **TURN THE COMPRESSOR OFF WHEN IT IS NOT IN USE**
When the compressor is not in use turn the main ON/OFF switch OFF (position "0").
26. **DO NOT TOUCH HOT PARTS OF THE COMPRESSOR**
To avoid scolding do not touch pipes, the motor or any other hot part.
27. **DO NOT DIRECT THE JET OF AIR DIRECTLY TOWARDS THE BODY**
To avoid all risks never direct the jet of air towards people or animals.
28. **DO NOT STOP THE COMPRESSOR BY PULLING ON THE POWER SUPPLY CABLE**
Use the "O/I" (ON/OFF) buttons of the control panel to stop the compressor.
29. **PNEUMATIC CIRCUIT**
Use recommended pneumatic hoses and tools that can withstand the same or a higher pressure than the maximum running pressure of the compressor.
30. **SPARE PARTS**
Use only original and identical spare parts to replace worn or damaged ones.
Repairs must be made exclusively by authorised service centres.
31. **CORRECT USE OF THE COMPRESSOR**
The operator must be perfectly familiar with all the controls and compressor characteristics before starting to work with the machine.
32. **MAINTENANCE JOBS**
The use and maintenance jobs of the commercial components fitted on the machine, but not indicated in this manual, are indicated in the enclosed documents.
33. **DO NOT UNSCREW THE CONNECTION WHEN THE TANK IS PRESSURISED**
Do not unscrew the connection for any reason whatsoever with the tank pressurised without first checking if the tank is discharged.
34. **DO NOT MODIFY THE TANK**
It is prohibited to intentionally drill, weld or deform the compressed air tank.
35. **IF THE COMPRESSOR IS USED FOR PAINTING JOBS**
a) Do not work in closed rooms or near free flames.
b) Ensure that the room in which you are working is sufficiently ventilated.
c) Wear face and nose mask.
36. **DO NOT PUT OBJECTS OR PARTS OF THE BODY IN THE PROTECTION GRIDS**
Do not put objects or parts of the body in the protection grids to prevent physical injuries and damage to the compressor.



KEEP THESE USE AND MAINTENANCE INSTRUCTIONS CAREFULLY AND GIVE THEM TO PERSONNEL WISHING TO USE THE COMPRESSOR!

WE RESERVE THE RIGHT TO MAKE MODIFICATIONS WHERE NECESSARY WITHOUT NOTICE.

2 Preliminary machine information

2.1 General description

The **rotary screw compressor** has been specifically designed aiming at minimising maintenance and labour costs. The outside cabinet is completely covered in sound-proof and oil-proof panelling thus ensuring its extended and lasting wear.

The components have been arranged so that all vital parts can be easily reached for maintenance purposes simply by opening dedicated panels with quick-release locking devices.

The filters and adjustment and safety devices (oil filter, air filter, oil separator filter, regulator valve, minimum pressure valve, max. pressure safety valve, thermostat, belt tightener, screw compression unit, pressure switch and oil separator tank emptying and filling taps) are all fitted on the same side.

The dryer series has been devised with the intention of enclosing a complete compressed air system in one compact machine. It is indeed connected to a dryer that is capable of supplying dry air to ensure the perfect and lasting use of the tools.

Note! **The tanks of the compressors have been manufactured in compliance with the EEC/2009/105 Directive for the European market.**
The compressors have been manufactured in compliance with the EC/2006/42 Directive for the European market.

Note! **Check your model on the identification nameplate fitted on the compressor. It is also indicated in this manual.**

ADVISED LUBRICANTS

Always use oil for turbines with approximately 46 cSt at 40°C and a pour point of at least -8 +10°C. The flash point must be greater than +200°C.



NEVER MIX DIFFERENT OIL QUALITIES.



**SCREW OIL
FIAC OIL D46**

Use oil with VG32 rating for cold climates and VG68 for tropical climates. It is advisable to use synthetic oils for very hot and humid climates.

2.2 Intended use

The silent rotary screw compressors have been designed and manufactured exclusively to produce compressed air. **EVERY OTHER USE, DIFFERENT AND NOT FORESEEN BY ALL INDICATED, RELIEVES THE MANUFACTURER OF POSSIBLE CONSEQUENT RISKS.**

In any event the use of the compressor different to that agreed in the purchase order **RELIEVES THE MANUFACTURER FROM ALL LIABILITIES WITH REGARD TO POSSIBLE MATERIAL DAMAGE AND PERSONAL INJURY.**

The electrical system is not designed for the use in environments subject to explosion or for flammable products.



NEVER DIRECT THE JET OF AIR TOWARDS PEOPLE OR ANIMALS. NEVER USE THE COMPRESSED AIR PRODUCED BY LUBRICATED COMPRESSORS FOR RESPIRATORY PURPOSES OR IN PRODUCTION PROCESSES WHERE THE AIR IS IN DIRECT CONTACT WITH FOODSTUFFS UNLESS IT HAS BEEN FIRST FILTERED AND CONDITIONED FOR SUCH PURPOSE.

2.3 Technical data

MODEL			Hp 3
Max. pressure	bar/psi	@50 Hz	9 – 130.5
		@60 Hz	7,5 - 109
Free air delivered ISO 1217 MAX	l/min - cfm	@50 Hz	300 – 10.6
		@60 Hz	310 – 10.9
Air outlet fitting	R		½ G
Oil q.ty	l		2
Oil residue in air	ppm		<3
Output	HP / kW		3 / 2,2
Service			S1
Max starts p/hour	N°		10
Ambient temperature range	°C (min/max)		5/40
Noise level*	dB (A)		59

* Sound level measured in a free range at a distance of 4 m: ±3dB(A) at the maximum working pressure

3 Transport, Handling, Storage



In order to use the compressor in complete safety read the safety standards given in section 1.3. before reading this section.

3.1 Transporting and handling the packed machine



The packed compressor must be transported by qualified personnel using a forklift truck.

Before moving the machine ensure that the load-bearing capacity of the forklift truck is sufficient to take the weight to be lifted.

Position the forks exclusively as illustrated.

Once the forks have been positioned in the points indicated, lift slowly without jerking.



Never stand near the area where the compressor is being handled and never stand on the crate while it is being moved.

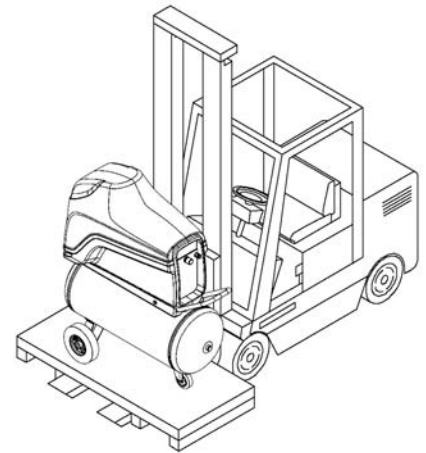

3.2 Packing, Unpacking and prepare to use

To avoid damages and to protect the compressor during transport it is usually placed into a carton box.

All the shipping and handling information and symbols are printed on the compressor packing.

Upon consignment remove the top part of the packing and check if any damages have been encountered during transport. If any damages are found, caused during transport, immediately make a written claim, backed up with photos of the damaged parts if possible and forward everything to your insurance company, with copy to the **Manufacturer** and transporter.

Using a forklift truck take the compressor as near as possible to the place where it is to be installed then carefully remove the protective packing without damaging it

Carefully ensure that the contents correspond with all written in the consignment documents.

Dispose of the packing in compliance with current standards in force in the country of installation.



Note!

The machine must be unpacked by qualified personnel using appropriate tools and equipment.

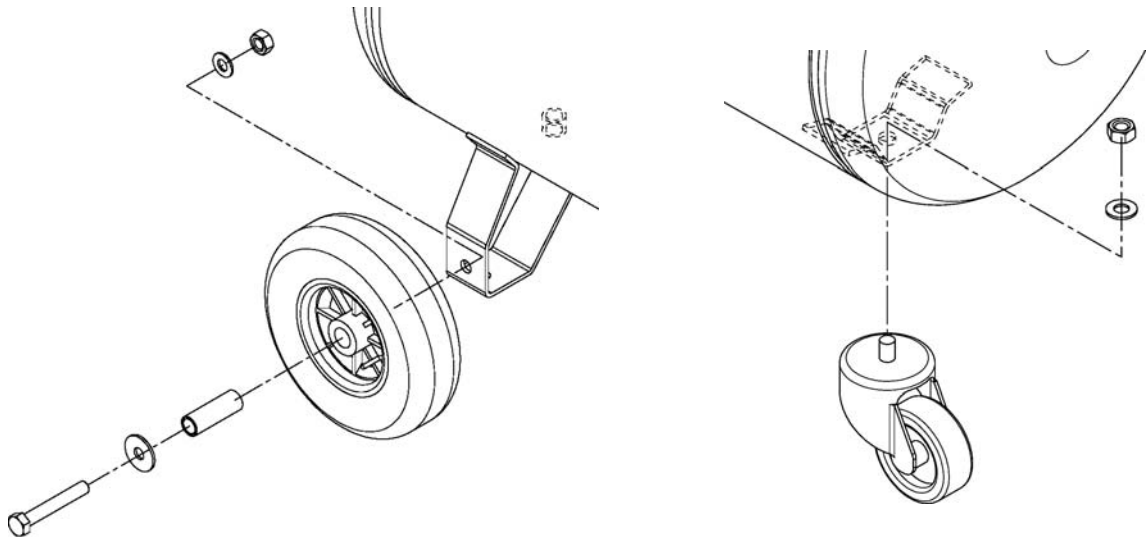

Remove the compressor from its packing (fig.1), make sure it is in perfect condition, checking if it was damaged during transport, and carry out the following operations:

- Fit the wheels and rubber tab on the tanks on which they are not already fitted, observing the instructions in figures. In case of inflatable wheels, the maximum inflation pressure must be of 1,6 bar (24 psi).
- Position the compressor on a flat surface or with a maximum permissible inclination of 10°, in a well aired place, protected against atmospheric agents and not in a place subject to explosion hazard.



ATTENTION! THE TRAILER-MOUNTED COMPRESSORS OF POWER EQUAL OR MORE THAN 3 HP, ARE INTENDED FOR INTERNAL USE ONLY.

If the surface is inclined and smooth, check if the compressor moves while in operation – if it does, secure the wheels with two wedges. If the surface is a bracket or a shelf top, make sure it cannot fall, securing it in a suitable way.

To ensure good ventilation and efficient cooling, the compressor's belt guard must be at least 100 cm from any wall.

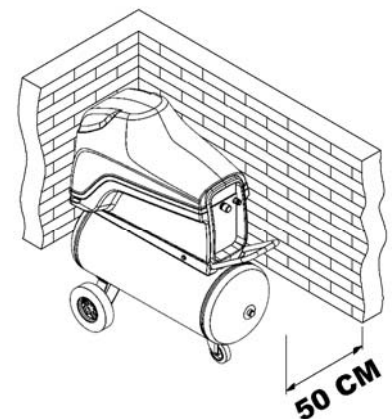

3.3 Storing the packed and unpacked compressor

For the whole time that the compressor is not used before unpacking it, store it in a dry place at a temperature between +5°C and + 40°C and sheltered away from weather.

For the whole time that the compressor is not used after unpacking it, while waiting to start it up or due to production stoppages, place sheets over it to protect it from dust, which may settle on the components.

The oil is to be replaced and the operational efficiency of the compressor is to be checked if it is not used for long periods.

4 Installation



In order to use the compressor in complete safety read the safety standards given in section 1.3. before reading this section.

4.1 Admitted surrounding conditions

Position the machine as established when the order was placed. Failing this the **Manufacturer** is not liable for any inconveniences that may possibly arise.

Unless pointed out otherwise when placing the order, the compressor must work regularly in the surrounding conditions indicated below:

ROOM TEMPERATURE

For a good work, the room temperature must not be lower than 5°C or higher than 40°C.

If the compressor works at a room temperature lower than the minimum value, the condensate could be separated within the circuit and therefore the water would mix with the oil, thus deteriorating the quality of the latter, failing to guarantee the even formation of the lubricating film between the moving parts with the possibility of seizure.

If the compressor works at a room temperature higher than maximum value, the compressor would take in air that is too hot, which would prevent the heat exchanger from adequately cooling the oil in the circuit, raising the working temperature of the machine, thus causing the thermal safety device to trip, which stops the compressor due to an excessive temperature of the air/oil mixture at the screw outlet.

The maximum temperature of the room is to be measured while the compressor is running.

LIGHTING

The compressor has been designed in compliance with legal prescriptions and in the attempt to minimise shadow zones to facilitate the operator's job.

The lighting system of the factory is to be considered as crucial for the operator's safety.

The room in which the compressor is installed must have no shadow zones, dazzling lights or stroboscopic effects due to the lighting.

ATMOSPHERE WITH RISK OF EXPLOSION AND/OR FIRE

The standard compressor is not pre-arranged or designed to work in rooms subject to the risk of explosion or fire. The performance of the compressor may decrease at the maximum permitted ambient temperature, with relative humidity higher than 80% and at an altitude of more than 1,000 mt.

4.2 Space required for maintenance

The compressor must be installed in a large room that is well-aired, dust-free and sheltered away from rain and frost. The compressor takes in a large amount of air that is required to ventilate it internally. A dusty atmosphere would in time cause damages and inefficient performance.

Part of the dust once inside is taken in by the air filter causing it to clog rapidly and another part of dust will settle on the components and will be blown against the cooling radiator, consequently compromising the efficiency of the heat exchanger. It is therefore obvious that the cleanliness of the area in which the compressor is installed is crucial for the correct efficiency of the machine, avoiding excessive running and maintenance costs. To facilitate maintenance jobs and to create a favourable circulation of air, the compressor must have a sufficient free space all around it (see par.3.2).

The room must be provided with outlets that lead outdoors near the floor and ceiling that will allow the natural circulation of air.

If this is not possible, install some fans or extractors that guarantee a higher air flow rate than 50% that taken in by the compressor. Min. flow m^3/h 2500.

Ducts for the inlet and outlet of the air can be used in unfavourable environments. These ducts must be the same size as the in-take and delivery grid. If these ducts are longer than 3 meters contact the **Authorised Service Centre**.

Note! A conveyance system can be fitted to recover the hot ventilation air delivered, which can be used to heat the room or for other purposes. It is crucial that the cross section of the system that recovers the hot air is greater than the total cross section of the grid slots plus the system must be equipped with a forced extraction system (extractor fan) to favour a constant downflow (min. sect. cm^2 1200).

4.3 Positioning the compressor

The compressor must be placed on a flat floor. Check the position before placement.

The machine does not need a foundation or of any specific preparation of the supporting surface.



Do not secure the compressor rigidly to the floor.

4.4	Connecting the compressor to the sources of energy and relative inspections.
4.4.1	Connecting the compressor to the electrical mains power supply



The compressor is to be connected to the electrical mains by the customer, to his exclusive liability, employing specialised personnel and in compliance with the Accident Prevention Norms EN 60204.

INSTRUCTIONS FOR CONNECTING TO EARTH

This compressor must be connected to earth while in use in order to safeguard the operator against electrical shocks. The electrical connection must be carried out by a skilled engineer. It is advisable never to dismantle the compressor or even to make any other connections. All repairs must be carried out exclusively by authorised service centres or other qualified centres. The earth wire of the power supply cable of the compressor must be connected only and exclusively to the **PE** pin of the terminal board of the actual compressor. Before replacing the plug of the power supply cable ensure that the earth wire is connected.

EXTENSION CABLE

Use only extension cables with plug and earth connection. Never use damaged or squashed extension cables. Ensure that the extension cable is in a good state of wear. When using an extension cable, ensure that the cross section of the cable is sufficient to convey the current absorbed by the product to be connected.

If the extension cable is too thin there could be drops in voltage and therefore loss in power and overheating of the equipment.

The extension cable of the three-phase compressors must have a cross section in proportion with its length: see table below:

CORRECT CROSS SECTION FOR THE MAXIMIM LENGTH OF 20 mt

Power Kw/HP	Rated voltage	Phase	Section
2,2/3 Avv. diretto (D.O.L)	220/240V	1 ph	6 mm²
	220/240V	3 ph	4 mm²
	380/415V	3 ph	2,5 mm²



Avoid any risk of electric shock. Never use the compressor with a damaged electrical cord or extension cables. Regularly check the cables. Never use the compressor in or near water or near a hazardous environment where they can be electric shock.

ELECTRICAL CONNECTION

SINGLE-PHASE

The **compressors** must be installed by a qualified engineer. The compressors are supplied with cable (1) with plug "CE" 16A 6h.

THREE-PHASE

The compressors type L1+L2+L3+N+PE version 380÷415V and L1+L2+L3+PE version 220÷240V must be installed by a qualified engineer.

The compressors are supplied with cable without plug.

It is advisable to install the connector, magneto thermal switch and fuses near the compressor (3 m away at the most). The magneto thermal switch and the fuses must have the characteristics indicated in the table below:

Potenza Kw/HP	Tensione nominale	Magnetotermico	Fusibile
2,2/3 Avv. diretto (D.O.L)	220/240V 1 ph	20 A	25 A
	220/240V 3 ph	16 A	20 A
	380/415V 3 ph	10 A	16 A

Note! The fuse parameters indicated in the table above refer to the **gl** type (**standard**). If cartridge fuses type **aM** are used (**delayed**) the parameters in the table are to be reduced by 20%. The parameters of the magneto thermal switches refer to switches type **K**.

Ensure that the installed power in kW is at least double the input of the electric motor.

The mains voltage must correspond with that indicated on the electrical data nameplate of the machine; the admitted tolerance must remain within +/- 6%.

EXAMPLE: Voltage 230V: minimum tolerance 216 Volt, maximum tolerance 244 Volt
Voltage 400V: minimum tolerance 376Volt, maximum tolerance 424 Volt

The plug of the power supply cable must never be used as a switch but must be plugged into a power socket that is controlled by an adequate differential switch (magneto thermal switch).



Never use the earth connection instead of the neutral. The earth connection must be achieved according to the EN 60204 industrial safety standards. Ensure that the mains voltage corresponds with that required for the correct operation of the compressor.

4 Installation

4.4.2 Connecting to the pneumatic mains



**Always use pneumatic hoses for compressed air with the maximum pressure characteristics and cross section suitable for those of the compressor.
Do not try to repair a faulty hose.**

Connect the compressor to the pneumatic mains using the quick coupler 1.

Use hosing with a greater or same diameter as the compressor outlet.

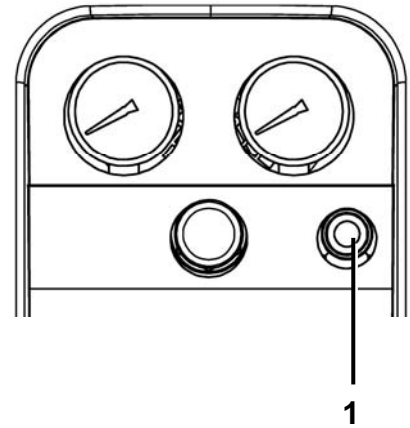



In order to use the compressor in complete safety read the safety standards given in section 1.3. before reading this section..

5.1 Preparing to use the compressor

5.1.1 Operational principle

The air taken-in by the filter passes through a valve that controls its flow rate to the screw where, mixing with the oil, it is compressed.

The air/oil mix produced by compression reaches a tank where the initial separation by gravity is achieved; as the oil is heavier, it settles on the bottom, it is then cooled and sent through a heat exchanger, filtered and injected into the screw again.

(The temperature is kept under control by an electric fan that is directly controlled by a thermostat). The oil is required to reduce the heat produced by compression, to lubricate the bearings and to maintain the coupling of the screw lobes. The air is sent through an oil separator filter to be additionally purified from residue oil particles. It is cooled by means of another heat exchanger and is finally outlet to be used at low temperature and with acceptable oil residues (<3p.p.m.). A safety system controls the crucial points of the machine and points out any abnormal conditions. The temperature of the air/oil mix at the screw outlet is controlled by a thermostatic probe placed into the Start/Stop button (single-phase ver.) or by "F1" thermal relay placed into the electrical cabinet (three-phase ver.), which stops the compressor if the temperature is too high.

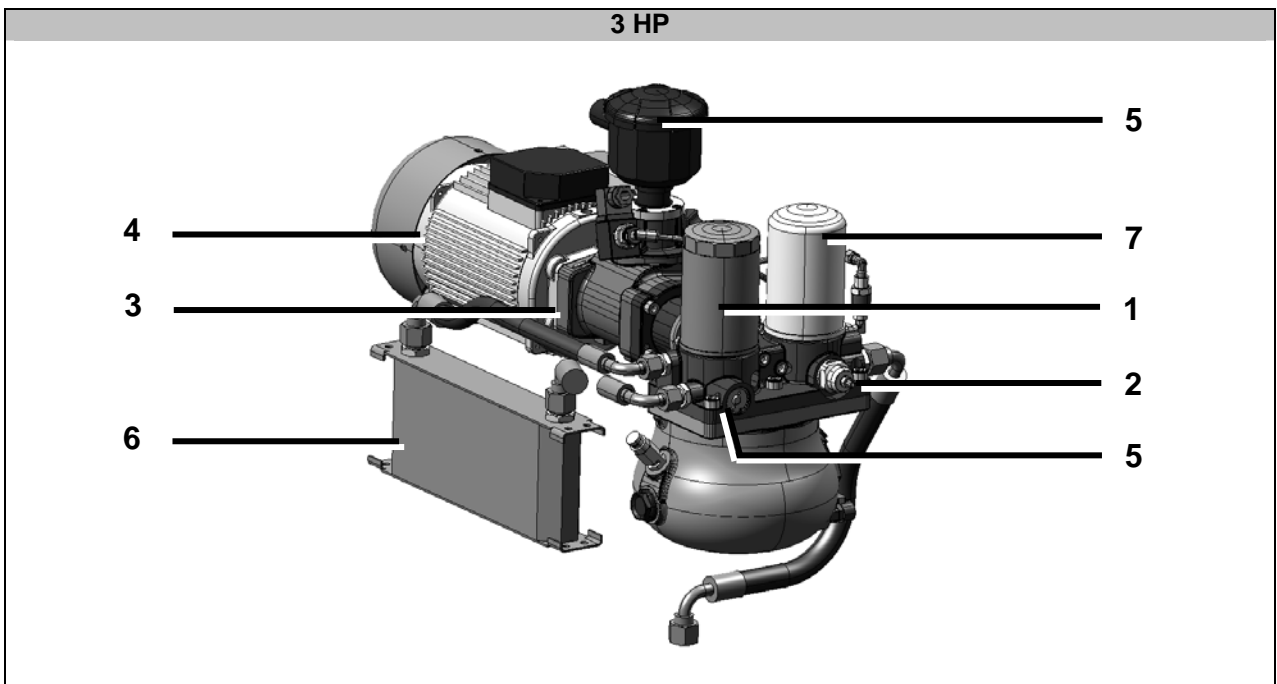

	GB	IT	DE	ES
1	Oil filter	Filtro olio	Oelfilter	Filtro aceite
2	Minimum pressure valve	Valvola minima pressione	Mindestdruckventil	Valvola presion minima
3	Air end	Gruppo vite	Schraubengruppe	Grupo tornillo
4	Electric motor	Motore elettrico	Elektromotor	Motor electrico
5	Air filter	Filtro aria	Luftfilter	Filtro aire
6	Oil radiator	Radiatore olio	Oelradiator	Radiator aceite
7	Oil separator	Filtro separatore	Oelabscheider	Filtro separador

5 Using the compressor

5.2 Control panel

1	OUTLET PRESSURE GAUGE
2	TANK PRESSURE GAUGE
3	PRESSURE REGULATOR
4	COMPRESSED AIR OUTLET
5	STOP/ EMERGENCY
6	START
7	HOURSCOUNTER
8	RESET BUTTON

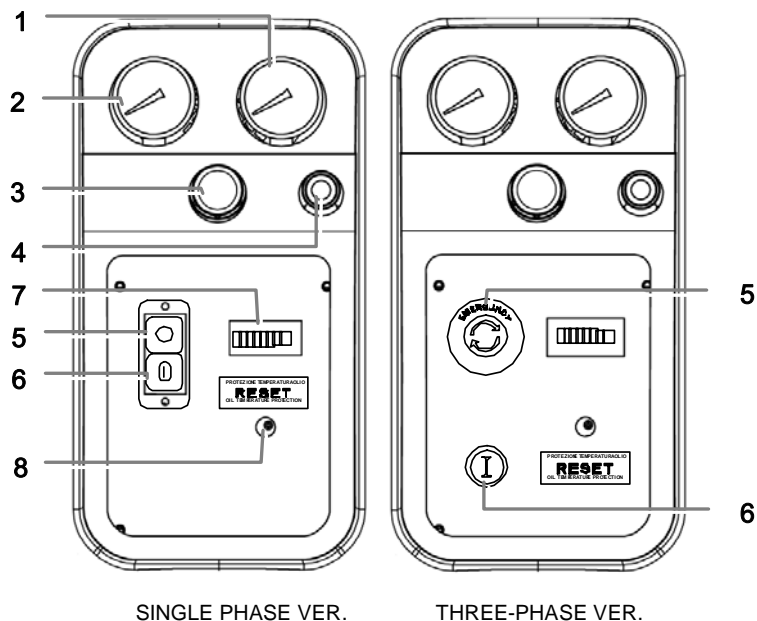

5.3 Check the efficiency of the safety devices before starting

OIL LEVEL

Check the oil level as indicated in Section 6 “Compressor maintenance”.

5.4 Starting the



Following an electrical shortage the compressor will start only if the START (I) button is pressed. Ventilation must occur as illustrated below.

It is of crucial importance that the compressor works with all the panels firmly closed.

The failed observance of these and the following standards may lead to accidents that could cause personal injury and serious damages to the compressor or its equipment.

Before initially starting the compressor or following extended inoperative periods, start the machine intermittently by pressing the START(I)-STOP(O) buttons on and off for 3 or 4 seconds. After this it is advisable to run the compressor for a few minutes with the air outlet tap open.

Then gradually shut-off the air tap and load to maximum pressure, checking if the inputs on each phase of the power supply are within the limits and also if the pressure switch trips.

At this stage, when the max pressure value is arrived, the pressure switch start the idle running for 2 minutes; after this time, if there's not air consumption, the compressor stop in stand-by condition. Discharge the air from the tank until the starting pressure is reached (2 bar difference compared to maximum pressure). Shut-off the air outlet tap and wait for the pressure switch to trip, which will shut-on the in-take valve and close the internal discharge.

CALIBRATION AND SETTINGS MADE BY THE MANUFACTURER

MODEL	SETTING
9 bar	7÷9 bar
7,5 bar	5,5÷7,5 bar

THREE-PHASE VERSION:

The thermal relay F1 (1) is setting as following:

Power	Nominal rate	
kW / HP	380/415V	220/240V
2,2 / 3	6,7 A	11,5 A

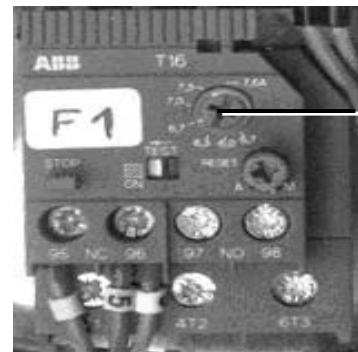

DISCONNECT THE ELECTRICAL POWER SUPPLY FORM THE COMPRESSOR BEFORE OPENING THE ELECTRICAL CABINET.

USEFUL TIPS FOR CORRECT COMPRESSOR PERFORMANCE

For the correct operational performance of the machine under full continuous load at the maximum working pressure, ensure that the temperature of the work area in a closed room does not exceed +45°C. It is advisable to use the compressor with a maximum service of 80% in one hour under full load in order to ensure the correct efficiency of the product in time.

5.5 Stopping the compressor

Press the **STOP** button on the control panel (see par. 5.2) the compressor fail immediately.

Note! By disconnecting the power supply from the external switch the compressor is completely without power.

6 Compressor maintenance



In order to use the compressor in complete safety read the safety standards given in section 1.3. before reading this section.

6.1 Instructions relative to inspections and maintenance jobs.

The table that follows summarises the periodic and preventative maintenance jobs required to keep the compressor in an efficient operational state in time.

A brief description of the running hours after which the type of maintenance job is required.



Before performing any jobs within the sound-proof cabinet, ensure that:

- The main line switch is turned off (position "0")
- The compressor is disconnected from the compressed air system
- All the pressure has been released from the compressor and internal pneumatic circuit.

Note! If the compressor is used for more than 3000 hours/year the jobs indicated herewith are to be performed more often.

MAINTENANCE SCHEDULE

PERIOD	Weekly	3 mesi	1° anno	2° anno	3° anno	4°anno	5°anno	6°anno	7°anno	8°anno
HOURS OF DUTY		500	2500	5000	7500	10000	12500	15000	17500	20000
GENERAL RECURRING CHECKS										
Drain the condensate	X									
Check oil level		X	X	X	X	X	X	X	X	X
Check electric connections		X	X	X	X	X	X	X	X	X
Check oil/air leaks	X	X	X	X	X	X	X	X	X	X
Check condensate into the oil		X	X	X	X	X	X	X	X	X
Functional check cooling fan		X	X	X	X	X	X	X	X	X
Functional check suction valve		X	X	X	X	X	X	X	X	X
Check oil recovery		X	X	X	X	X	X	X	X	X
Check pressure setting		X	X	X	X	X	X	X	X	X
AIR/OIL CIRCUIT										
Replace air filter cartridge			X	X	X	X	X	X	X	X
Replace oil filter cartridge		X	X	X	X	X	X	X	X	X
Replace oil separator filter cartridge		X	X	X	X	X	X	X	X	X
Oil change		X	X	X	X	X	X	X	X	X
Cleaning air/oil radiator			X	X	X	X	X	X	X	X
Oil recovery overhaul				X		X		X		X
Suction valve overhaul				X		X		X		X
Replace hydraulic hoses						X				X
Minimum pressure valve overhaul						X		X		
ELECTRICAL CIRCUIT										
Check / replace pressure switch / transducer				X		X		X		X
Check / replace solenoid				X		X		X		X
Check / replace temperature probe				X		X		X		X
MAINTENANCE										
Replace electrical motor bearings						X		X		
Screw unit total overhaul										X
Replace screw unit seal						X				X
Replace security valve						X		X		

The above described maintenance schedule has been planned bearing in mind all the installation parameters and recommended use of the Manufacturer.

The Manufacturer advises the customer to keep a record of all maintenance jobs performed on the compressor, see Section 7 – Drawings and diagrams.

6.1.1 Oil change



Read all the information provided in **Section 6.1** before proceeding with any maintenance jobs.

Change the oil following the initial **500 hours** of use and then every **2500 hours** and in event once a year. **In case of not frequently use (few hours of duty per day) you should change the oil every 6 months.**

Open the shroud



A

Unscrew the cap **1** situated at the base of the screw unit.

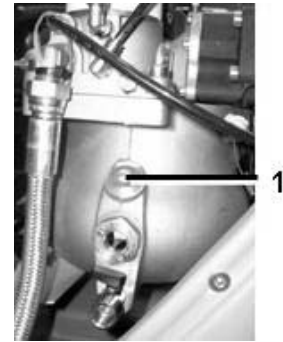

B

Screw an attachment with tail piece **2** (supplied with the compressor).

Open tap **3**.



Once emptied, shut-off tap **3** and remove the attachment with tail piece.

C

Fill-up with oil to the half of the union **4**, then screw cap **1** back in place and close-up the compressor again.

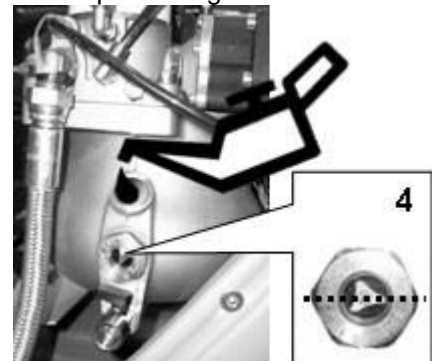

Once the oil and oil filter have been changed leave the compressor to run for roughly 5 minutes then turn it off and check the oil level again. Add oil if necessary.

Check the oil level once a month.

D

6 Compressor maintenance

6.1.2 Replacing the oil filter cartridge



Read all the information provided in **Section 6.1** before proceeding with any maintenance jobs.



Replace the oil filter cartridge after the first 500 hours of use then every 2500 hours and in any event each time the oil is changed.

Remove the upper plastic shroud to gain access to inside the compressor.

Disassemble filter cartridge 1, using a chain spanner and replace with a new one.

Lubricate the sealing gasket before screwing the filter cartridge tight.

Manually tighten the new filter cartridge.

6.1.3 Replacing the oil separator filter cartridge.



Read all the information provided in **Section 6.1** before proceeding with any maintenance jobs.



Replace the oil separator filter cartridge after the first 500 hours of use then every 2500 hours and in any event each time the oil is changed.

Remove the upper plastic shroud to gain access to inside the compressor.

Disassemble filter cartridge 2, using a chain spanner and replace with a new one.

Lubricate the sealing gasket before screwing the filter cartridge tight.

Manually tighten the new filter cartridge.

6.1.4 Replacing the air filter cartridge



Read all the information provided in **Section 6.1** before proceeding with any maintenance jobs.



Remove the upper plastic shroud to gain access to inside the compressor.

Open the plastic cover.
Replace the air filter cartridge and replace the cover.

6.1.5 Draining the condensate



Read all the information provided in **Section 6.1** before proceeding with any maintenance jobs.

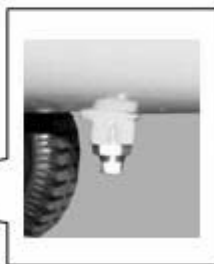

Drain the condensate from the air tank at least once a week by opening the draining valve under the tank.



The condensate drained is considered as polluting mix that must not be thrown away outdoors. It is advisable to use special water/oil separators for its disposal.

6 Compressor maintenance

6.1.6 Cleaning the air/oil radiator



Read all the information provided in **Section 6.1** before proceeding with any maintenance jobs.



Remove upper and under plastic shrouds to gain access to inside the compressor.

Blow compressed air through the radiator, from inside outwards, making sure that no dirt settles inside the compressor.

6.1.7 Electric motor maintenance

The bearings of the electric motor are already lubricated and are maintenance free.

In normal surrounding conditions (ambient temperature up to 30°C) replace the motor bearings every 12500 hours of use. In more severe surrounding conditions (ambient temperature up to 40°C) replace the motor bearings every 5000 hours of use.

The bearings are to be replaced in any event every 3 years at the most.



Before replacing the motor bearings, contact our customer service department, as established by the maintenance schedule.



6.2 Diagnosing the alarm status/inconveniences-faults



Before doing any job on the compressor ensure that:

- The main ON/OFF switch is turned Off (position “0”)
- The button EMERGENCY/STOP is pressed in security position
- The compressor is shut-off from the compressed air system
- The compressor and the internal pneumatic circuit are completely de-pressurised.

If you are unable to rectify the anomaly encountered on your compressor contact your nearest authorised service centre.

Anomalies	Causes	Solutions
The compressor do not start	Single-phase No power from the main.	Check and restore the power main.
	Three phase No power from the main. Wrong rotating direction	Check and restore the power main. Invertire una fase di alimentazione (L1-L2-L3) sulla spina.
The compressor stops: intervention of the thermal protection.	Single and Three-phase Excessive temperature of air/oil mix	<ul style="list-style-type: none"> - Check the oil level - Check the radiator cleaning <p>To restore the compressor proceed as follows:</p> <div style="display: flex; align-items: flex-start;"> <div style="flex: 1;">  </div> <div style="flex: 1; padding-left: 10px;"> <p>Unscrew the protection cap</p> </div> </div> <div style="display: flex; align-items: flex-start; margin-top: 10px;"> <div style="flex: 1;">  </div> <div style="flex: 1; padding-left: 10px;"> <p>Press with a pointed object until it clicks.</p> </div> </div>

Anomalies	Causes	Solutions
<p>The compressor stops.</p>	<p><i>Single-phase</i> Motor overheating: intervention of the motor thermal protection.</p>	<ul style="list-style-type: none"> - Check the electrical power is correct. - Check the cables are firmly fitted to the terminal board. - Check if the electrical cables have melted. - Check if the fan motor intake grid is clean or obstructed (paper, leaves, ragis). <p>To restart the compressor await a few minuts and press the START button on the control panel.</p>
	<p><i>Three-phase</i> Motor overheating: Intervention of the motor thermal relay.</p>	<ul style="list-style-type: none"> - Check the electrical power is correct. - Check the cables are firmly fitted to the terminal board. - Check if the electrical cables have melted. - Check if the fan motor intake grid is clean or obstructed (paper, leaves, ragis). <p>To restart the compressor await a few minuts and press the F1 thermal relay RESET button inside the electrical cabinet.</p>

7.1 Wiring diagrams

Hp 3 220+240 V – 50/60 Hz – 1 ~

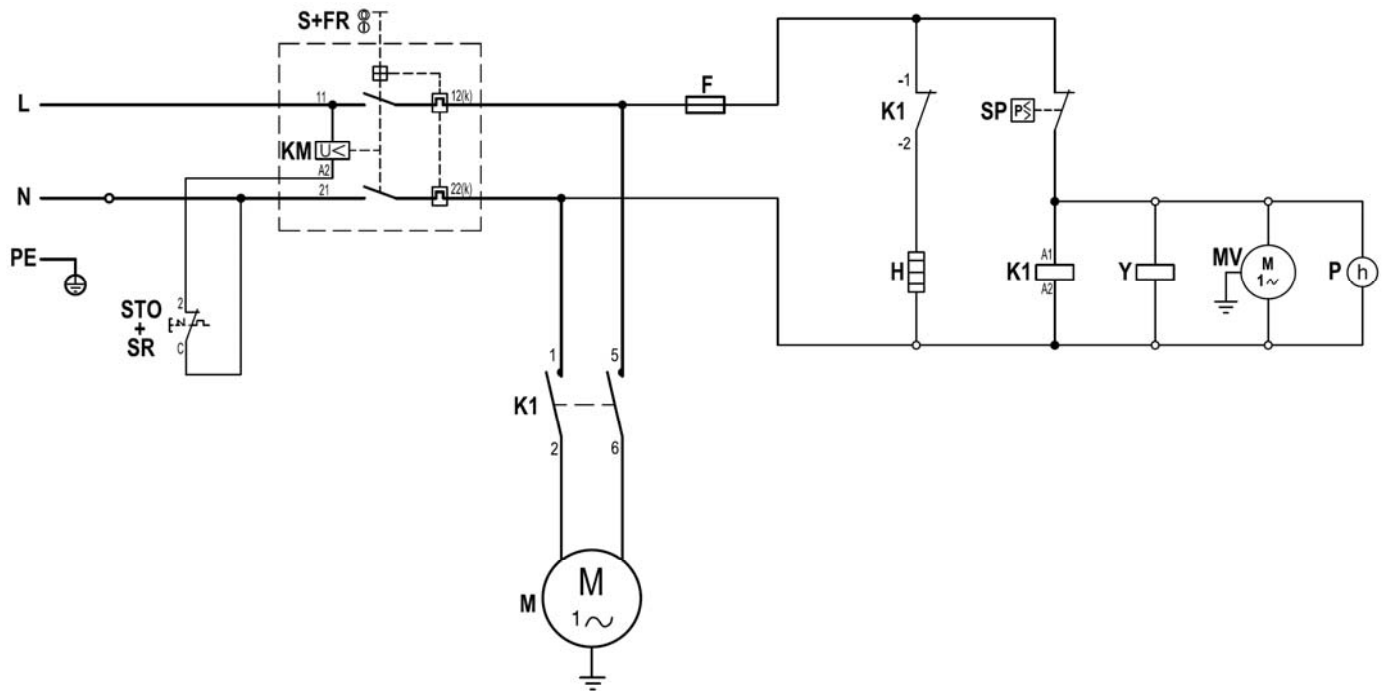

LEGENDA

S+FR	START-STOP SWITCH WITH THERMAL PROTECTION
STO+SR	THERMOSTAT TEMPERATURE SCREW UNIT OIL + RESET
H	HEATER
KM	MIN VOLTAGE RELAY
K1	MOTOR COMPRESSOR CONTACTOR
SP	PRESSOSTAT
Y	SOLENOID
F	FUSE
P	HOUR COUNTER
M	COMPRESSOR MOTOR
MV	FAN MOTOR

Hp 3 220+240 V – 50/60 Hz – 3 ~

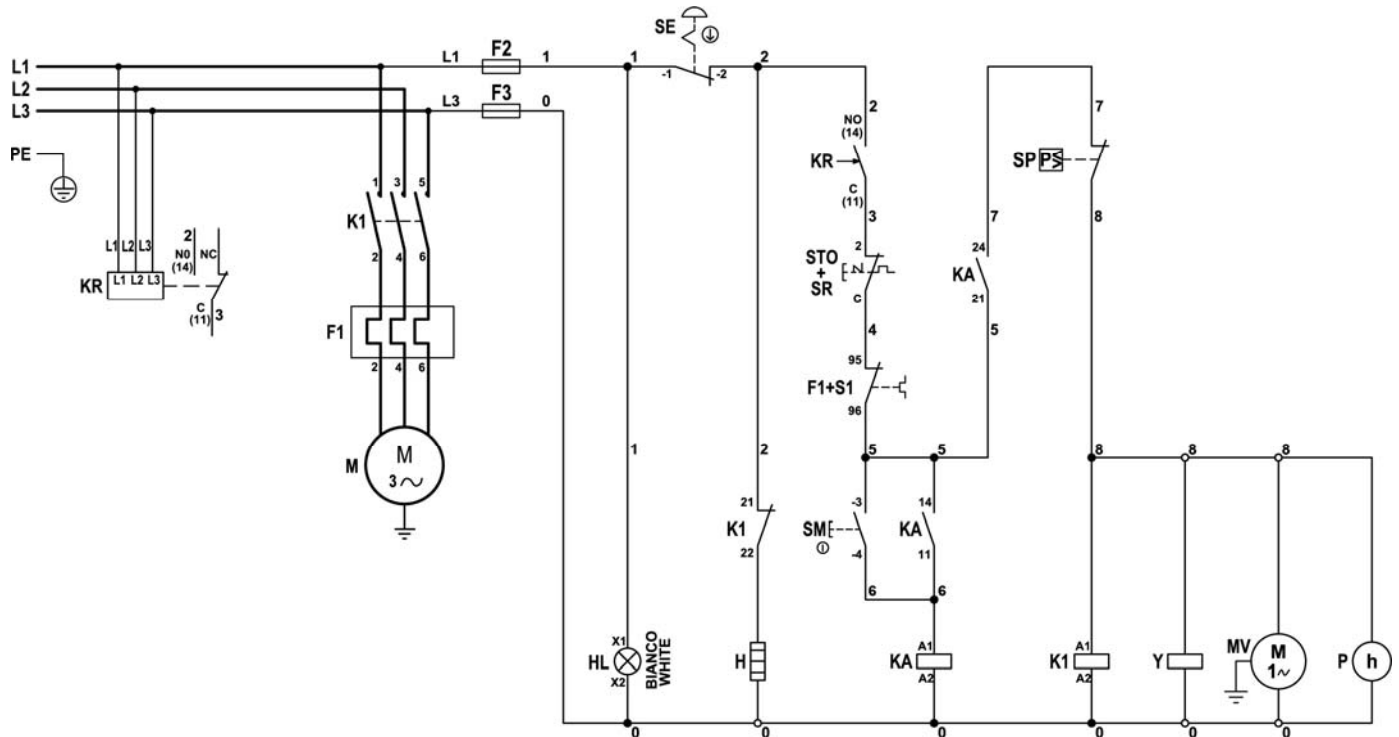

KEY:

F2-F3	FUSES 5x20 1,6 A (F)
HL	STATUS LAMP
SM	COMPRESSOR START BUTTON
SE	EMERGENCY BUTTON
STO+SR	SCREW OIL TEMEPRATURE THERMOSTAT+RESET
F1+S1	CMPRESSOR MOTOR THERMAL SWITCH WITH RESET
H	HEATER
K1	COMPRESSOR MOTOR CONTACTOR
KA	AUXILIARY RELAY
KR	PHASE SEQUENCY RELAY
SP	PRESSURE SWITCH
Y	SOLENOID VALVE
P	HOURS METER
M	COMPRESSOR MOTOR
MV	FAN MOTOR

Hp 3 380+415 V – 50/60 Hz – 3 ~

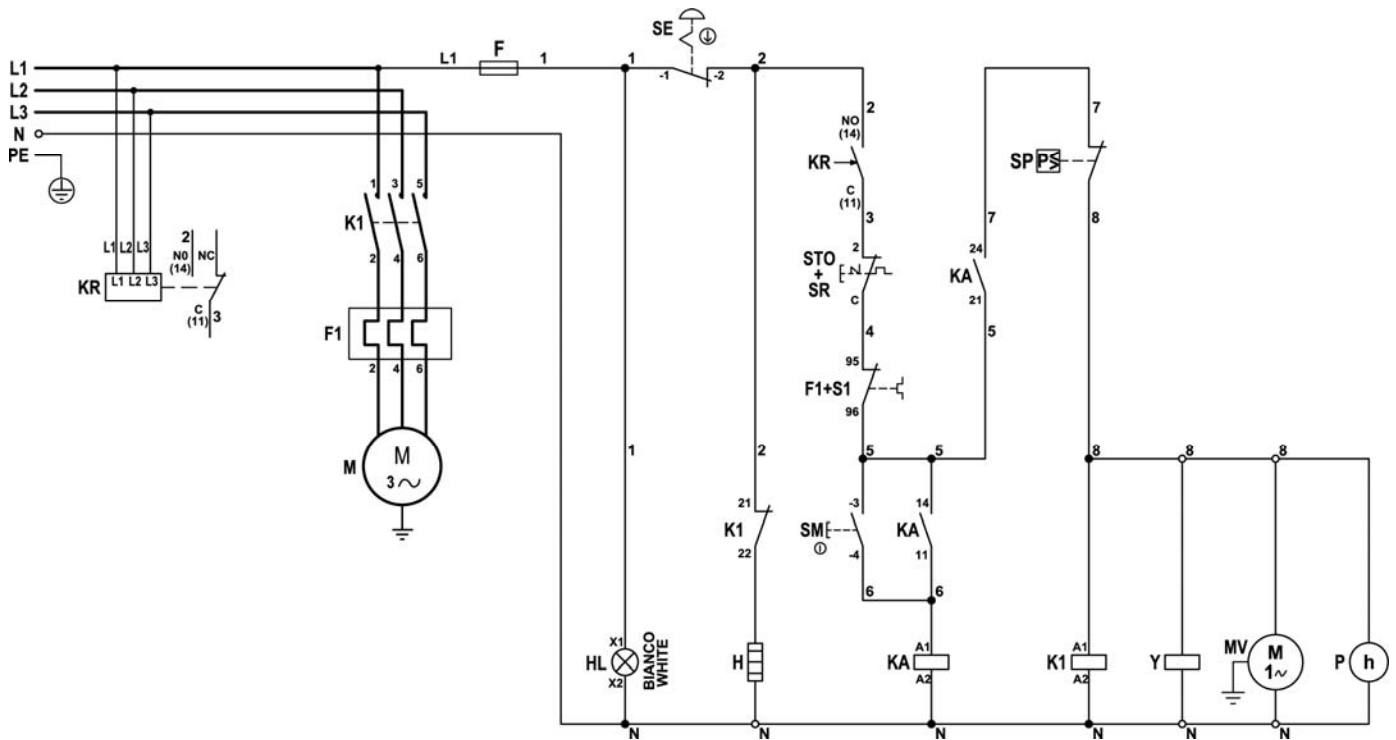

KEY:

F	FUSE 5x20 1,6 A (F)
HL	STATUS LAMP
SM	COMPRESSOR START BUTTON
SE	EMERGENCY BUTTON
STO+SR	SCREW OIL TEMPERATURE THERMOSTAT + RESET
F1+S1	COMPRESSOR THERMAL TRIP SWITCH + RESET
H	HEATER
K1	COMPRESSOR MOTOR CONTACTOR
KA	AUXILIARY RELAY
KR	PHASE SEQUENCY RELAY
SP	PRESSURE SWITCH
Y	SOLENOID VALVE
P	HOURS METER
M	COMPRESSOR MOTOR
MV	FAN MOTOR

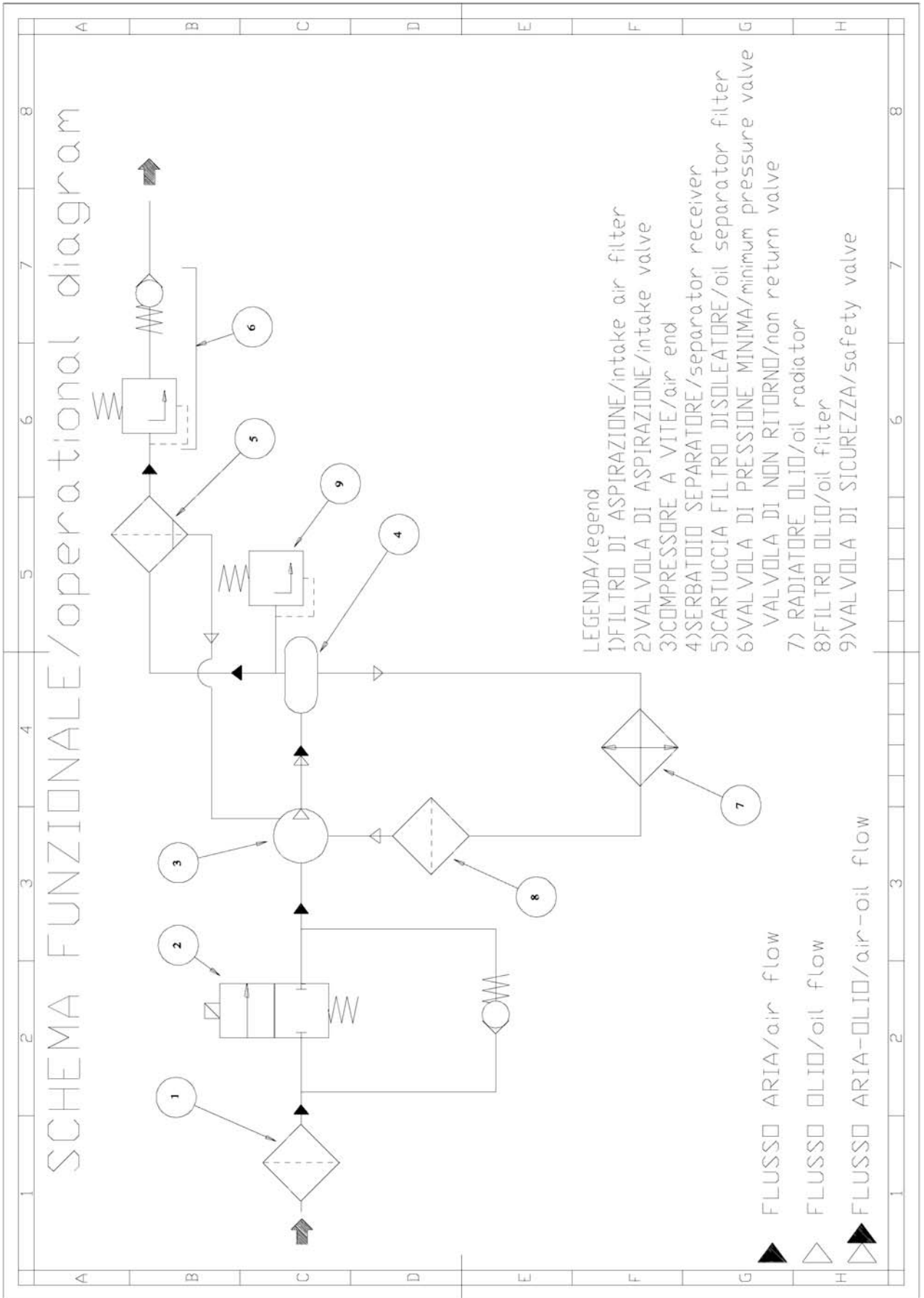

Maintenance program			
Model		Serial	

Date	Intervention	Hours of duty	Operator sign

Maintenance program			
Model		Serial	

Date	Intervention	Hours of duty	Operator sign

